

VACUUM CHUCKS

Model KVR VACUUM CHUCK

Vacuum system required additionally

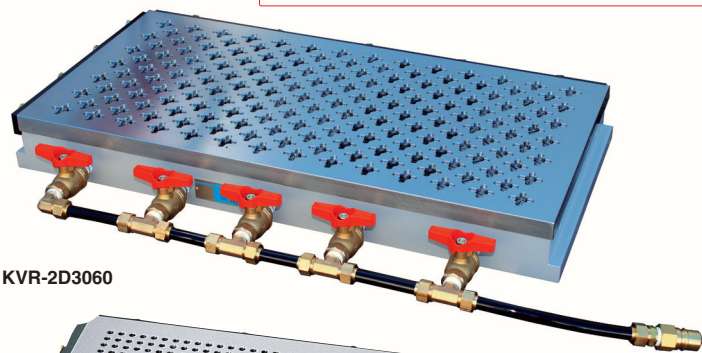

KVR-2D3060



KVR-H1530



An example of fabrication of special type

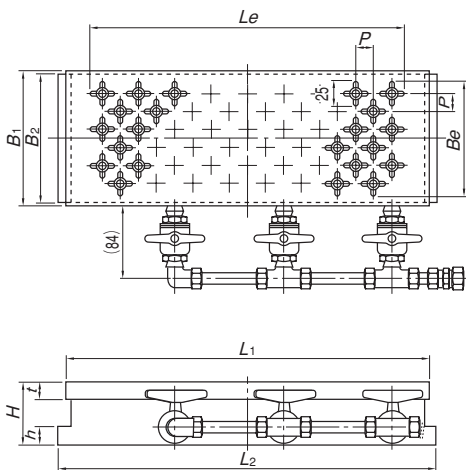

[Application]

Chucks to hold workpieces by utilizing atmospheric pressure. Nonferrous and nonmagnetic materials can be held and machined. These chucks are suitable for grinding and cutting plastics and grinding aluminum, brass, stainless steel, ceramic and glass.

[Features]

- The suction holes on the chuck work face can be arranged to set an effective holding area according to shapes of workpieces by combined adjustment of thread valves and valves.
- The suction holes have cross grooves to expand the acting area. Thus, fewer thread valves are used to improve the work efficiency.
- The chuck work face is made of iron to allow self-grinding to recover parallelism.
- Since the chuck work face is made of iron, magnetic devices such as workpiece stoppers can be utilized.
- A special suction hole layout adapter can be installed according to workpieces and work procedures.
- These chucks can be mounted on magnetic chucks.
- Since no heat source or moving parts are used inside the chucks, highly precise machining is ensured.

■ KVR-D (Thread valve type)

- An effective holding area can be set according to shapes of workpieces by combined adjustment of thread valves and valves.
- Since suction grooves of cross shape are provided on the holding face, the number of thread valves has been reduced to enhance the work efficiency.

■ KVR-H (Small hole type)

- Holes of $\phi 4$ are provided on the holding face at 8-mm pitches.

<Precautions for use>

The vacuum chuck is of such construction that the inside of the chuck is evacuated by a vacuum pump to reduce the internal pressure and a workpiece is held by atmospheric pressure. Therefore, the holding power is determined by a difference between the internal pressure and atmospheric pressure and the holding area. Due to physical restrictions, a difference in pressure that can be obtained by a pump is about 80 kPa (600 mmHg) in consideration of the upper limit of available evacuation efficiency. Since the same holding power as about 80 kPa (0.8 kgf/cm²) can be obtained, if the holding area of a workpiece is 100 cm², it is held by a holding power of about 800 N (80 kgf). Note, however, that if the holding face of workpieces is rough or distorted, even if slightly, atmospheric pressure leak occurs to decrease the holding power significantly. For such workpieces, some leak preventing measures must be taken. Workpieces could be deformed by heat generated during machining depending on materials and thickness of workpieces. Pay attention to machining methods. In particular, thin stainless steel sheets deform due to machining heat largely and are difficult to hold. If you have questions, please contact us.

[mm (in)]

Model	Nominal Size	Work Face					Hole Pitch	Mounting Face			Height	Mass	Applicable Vacuum System
		B ₁	L ₁	t	B _e	L _e		B ₂	L ₂	h			
KVR-2D1018	100 (3.93) × 175 (6.89)	100 (3.93)	175 (6.89)	20 (0.78)	85 (3.34)	145 (5.70)	P=20 (Staggered layout) (0.78)	96 (3.78)	195 (7.67)	20 (0.78)	70 (2.75)	9kg/ 19 lb	VPU-E10 VPU-E20 VPU-D20
KVR-2D1325	125 (4.92) × 250 (9.84)	125 (4.92)	250 (9.84)		105 (4.13)	225 (8.85)		121 (4.76)	270 (10.6)			15kg/ 33 lb	
KVR-2D1515	150 (5.90) × 150 (5.90)	150 (5.90)	150 (5.90)	125 (4.92)	125 (4.92)	170 (6.69)		11kg/ 24 lb					
KVR-2D1530	150 (5.90) × 300 (11.8)		300 (11.8)	245 (9.64)	320 (12.6)	22kg/ 48 lb							
KVR-2D1545	150 (5.90) × 450 (17.7)	200 (7.87)	450 (17.7)	405 (15.9)	470 (18.5)	33kg/ 72 lb							
KVR-2D2035	200 (7.87) × 350 (13.7)		350 (13.7)	305 (12.0)	370 (14.5)	34kg/ 74 lb							
KVR-2D2050	200 (7.87) × 500 (19.6)	500 (19.6)	465 (18.3)	520 (20.4)	49kg/ 108 lb								
KVR-2D3060	300 (11.8) × 600 (23.6)	300 (11.8)	600 (23.6)	285 (11.2)	545 (21.4)	296 (11.6)		620 (24.4)	88kg/ 194 lb	VPU-E20 VPU-D20			
*Clamp parts are included.													
KVR-H1018	100 (3.93) × 175 (6.89)	100 (3.93)	175 (6.89)	20 (0.78)	72 (2.83)	125 (4.92)	P=8 (0.31)	96 (3.78)	195 (7.67)	20 (0.78)	70 (2.75)	9kg/ 19 lb	VPU-E10 VPU-E20 VPU-D20
KVR-H1325	125 (4.92) × 250 (9.84)	125 (4.92)	250 (9.84)		92 (3.62)	205 (8.07)		121 (4.76)	270 (10.6)			15kg/ 33 lb	
KVR-H1515	150 (5.90) × 150 (5.90)	150 (5.90)	150 (5.90)		105 (4.13)	125 (4.92)		170 (6.69)	11kg/ 24 lb				
KVR-H1530	150 (5.90) × 300 (11.8)		300 (11.8)		252 (9.92)	320 (12.6)		22kg/ 48 lb					
*Clamp parts are included.													