

Model OC OIL ELIMINATOR

A powerful tool to assist purification of coolant.

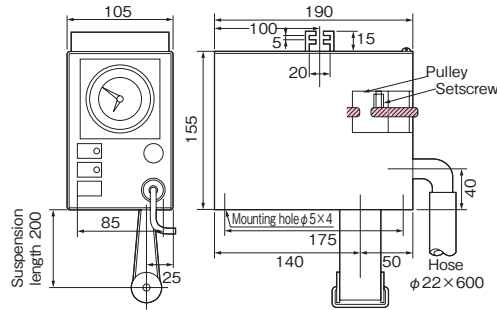

An example of usage

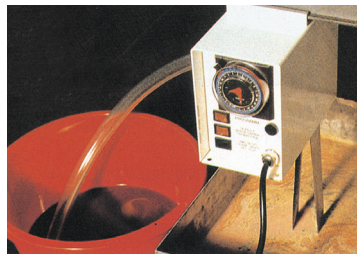

This model is designed to separate and collect oil films floating on the surface of liquid in waste liquid tanks of grinding fluid (coolant) and washing liquid by a special endless belt to assist purification and recycling of liquid.

[Application]

- Collection of floating oil in machined parts washing tanks and degreasing processes.
- Collection of oil in water soluble grinding coolant.
- Collection of oil floating in plant waste water.

[Features]

- This oil eliminator eliminates oil films efficiently and automatically discharges them as waste oil.
- Simple casing, light weight and compact for installation in limited space.
- Compared with the filter system, the endless belt has a longer service life and the running cost is very low.
- The belt is highly resistant to heat and chemicals and can be used with acid, alkali and chemical products. (However, when liquid is hot, its viscosity drops to affect the collection efficiency.)
- The eliminator can be run continuously or controlled by a timer or programs. The 24-hour timer can be set to any intervals in increments of 10 minutes for intermittent operation.
- In addition to the standard belt (suspension length: from bottom of main unit to center of weight 200 mm/belt width 40 mm), special types such as L=250, L=300 and heat resistance (100°C) specifications are also available.

Model	Capacity	Power Source	Motor	Mass	Remarks
OC-2	4L/h	Single-phase 200 VAC	3.5W	4.2kg/9.2 lb	Changeable to 100 VAC

※The power source can be changed to a single-phase, 100V only by changing internal wiring.
 ※Accessories 1. Standard belt (suspension length: from bottom of main unit to center of weight 200 mm/belt width 40 mm) × 1
 2. Discharge hose (overall length 600 mm/OD φ22 mm) × 1

Model KBS BARREL TYPE SEPARATOR

An example of fabrication

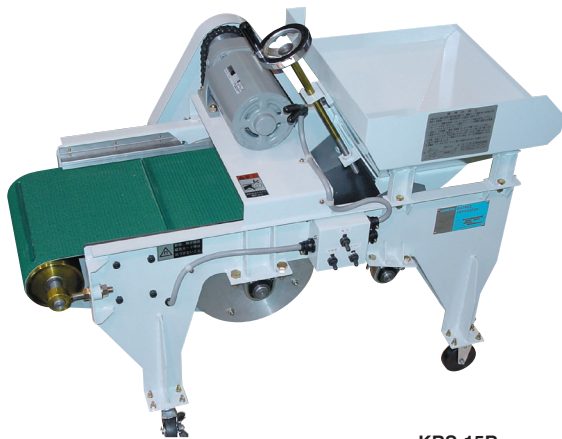

KBS-15B

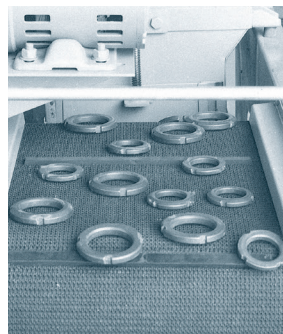

[Application]

This model is designed to automatically separate media and iron products after barrel polishing. It can also be applied to such operation as to automatically separate iron chips from nonferrous chips and products from polishing media.

[Features]

- The powerful permanent magnetic drum ensures efficient separation.
- Since a demagnetizer is provided under the transfer belt as a standard feature, workpieces can be demagnetized as needed.
- Casters facilitate relocation and installation.

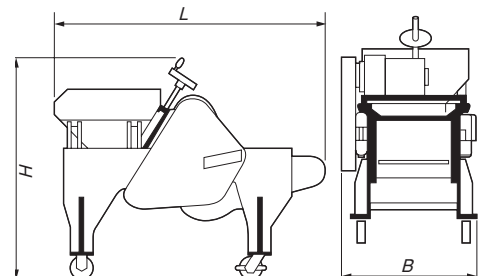

[mm (in)]

Model	Processing Capacity	Power Source	Motor	Demagnetizer Capacity		Hopper Volume	Dimensions			Mass
				Current	Capacity		L	B	H	
KBS-15B	20L/min	Single-phase 100 VAC	100W	9A	0.9kVA	20L	955 (37.6)	460 (18.1)	795 (31.3)	100kg/220 lb
KBS-30B	30L/min	3-phase 200 VAC	200W	10A	2kVA	30L		590 (23.2)		145kg/319 lb

MAGNETIC TOOL & EQUIPMENT FOR MACHINE OPERATION
 LIFTING MAGNET
 MAGBORE*
 OHP & SLIDE CONVENIENCE EQUIPMENT
 ENVIRONMENTAL EQUIPMENT
 MAGNETIZER AND DEMAGNETIZER FOR CONVENIENCE EQUIPMENT
 MAGNETIC EQUIPMENT FOR CONVENIENCE EQUIPMENT
 SEPARATORS, SEPARATORS
 POWERFUL MAGNETIC TOOLS
 MEASURING INSTRUMENTS
 MAGNETIC MATERIALS