

PERMANENT ELECTROMAGNETIC CHUCKS

Model EP-Q PERMANENT ELECTROMAGNETIC CHUCK FOR CUTTING

A Line-up of products selectable according to machining methods and workpieces.

- Considerable power saving and reduction in size of the Chuck Master by the renewed design.
- The detachable connector type is employed to respond to pallet changing.
- Electricity is used only when mounting and demounting workpieces. Workpieces can be held firmly in the event of power failure.
- Usable in wet machining operations.



[Application]

Suitable for securing workpieces during cutting on milling machines and machining centers.

[Features]

- The power cord is of detachable connector type for easy use. The connector cap is of waterproof type.
- Can be used in wet machining operations.
- The chuck is very thin, 70 mm in height, and light weight.
- Less accuracy change and highly rigid construction.
- Considerable power saving compared with conventional products. (□70: 50% reduction, □50: 70% reduction)

- Magnetization and demagnetization in a very short time.
- Tapped holes on the attractive face can be used to install various blocks to hold workpieces by various methods according to machining operations.
- Straightening blocks are also available that are mounted on the chuck work face to hold workpieces by an induction field. These optional products are very useful for workpieces having irregular attractive faces that for example have steps and distortion and for machining the bottom and side faces of workpieces. (See ■ Options on page 32.)

EP-QN Series



EP-QN7-50100A



Chuck controller required additionally

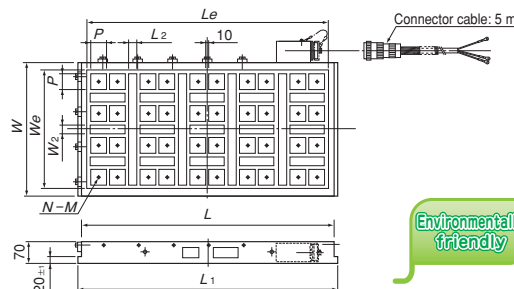

Environmentally friendly

[mm (in.)]

Standard Size Model	Work Face		Pole Dimensions				Mounting Face		Tapped Hole on Attractive Face		Mass	Applicable Chuck Master			
	W	L	We	Le	No. of poles	P	W _c	L ₂	L ₁	N			M		
EP-QN5	3060A	300 (11.8)	610 (24.0)	252 (9.92)	570 (22.4)	24	50 (1.96)	18 (0.70)	16 (0.63)	630 (24.8)	24 (0.94)	8 (0.31)	90kg/198 lb	EPS-P2100B	
	4080A	420 (16.5)	800 (31.5)	372 (14.6)	760 (29.9)	40		28 (1.10)	25 (0.98)	820 (32.2)	40 (1.57)		160kg/352 lb		
	50100A	500 (19.6)	960 (37.8)	432 (17.0)	917 (36.1)	60		18 (0.70)	26 (1.02)	980 (38.5)	60 (2.36)		230kg/507 lb		
	60100A	600 (23.6)		552 (21.7)		72		24 (0.94)			72 (2.83)		280kg/617 lb		
EP-QN7	4080A	390 (15.3)	800 (31.5)	332 (13.0)	760 (29.9)	24	70 (2.75)	28 (1.10)	820 (32.2)	24 (0.94)	24 (0.94)	10 (0.39)	150kg/330 lb	EPS-P2100B	
	50100A	500 (19.6)	1000 (39.4)	452 (17.8)	960 (37.8)	40				25 (0.98)	1020 (40.1)		40 (1.57)	240kg/529 lb	EPS-P2100B-2
	60100A	620 (24.4)	572 (22.5)	50	50 (2.36)	300kg/661 lb									

*Turning the permanent electromagnetic chucks on and off must be limited to once per several minutes. If on/off operations are repeated frequently, the chucks may be damaged by overheat.

EP-QS Series



EP-QS5-3060A



Chuck controller required additionally

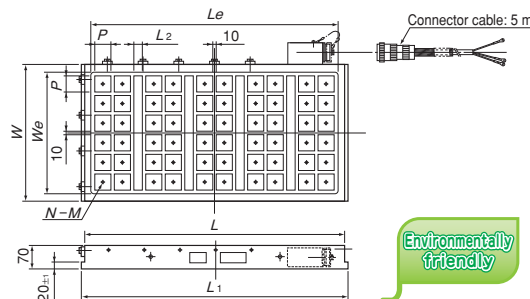

Environmentally friendly

[mm (in.)]

Standard Size Model	Work Face		Pole Dimensions				Mounting Face		Tapped Hole on Attractive Face		Mass	Applicable Chuck Master	
	W	L	We	Le	No. of poles	P	L ₂	L ₁	N	M			
EP-QS5	3060A	300 (11.8)	610 (24.0)	252 (9.92)	570 (22.4)	32	50 (1.96)	16 (0.55)	630 (24.8)	32 (1.26)	8 (0.31)	90kg/198 lb	EPS-P2100B
	4080A	420 (16.5)	800 (31.5)	372 (14.6)	760 (29.9)	60		25 (0.98)	820 (32.2)	60 (2.36)		160kg/352 lb	
	50100A	500 (19.6)	960 (37.8)	432 (17.0)	917 (36.1)	84		26 (1.02)	980 (38.5)	84 (3.31)		230kg/507 lb	
	60100A	600 (23.6)		552 (21.7)		108				108 (4.25)		280kg/617 lb	
EP-QS7	3060A	300 (11.8)	600 (23.6)	252 (9.92)	562 (22.1)	18	70 (2.75)	25 (0.98)	620 (24.4)	18 (0.70)	10 (0.39)	86kg/189 lb	EPS-P2100B
	4080A	390 (15.3)	800 (31.5)	332 (13.0)	760 (29.9)	32		24 (0.94)	820 (32.2)	32 (1.26)		150kg/330 lb	
	50100A	470 (18.5)	1000 (39.4)	412 (16.2)	960 (37.8)	50		25 (0.98)	1020 (40.1)	50 (1.96)		220kg/485 lb	
	60100A	620 (24.4)	572 (22.5)	70	70 (2.75)	300kg/661 lb							

*Turning the permanent electromagnetic chucks on and off must be limited to once per several minutes. If on/off operations are repeated frequently, the chucks may be damaged by overheat.

ELECTROMAGNETIC CHUCK CONTROLLERS: MAGNETIC CHUCKS EQUIVALENT ELECTROMAGNETIC CHUCKS
BLOCKS FOR MC
VACUUM CHUCKS
PROMETA*
SINE BAR CHUCKS
BLOCKS HOLDERS
HOLDING TOOLS
MEASURING TOOL HOLDERS
MAGNETIC HOLDERS
MAGNETIC TOOLS

Model designation

CHUCK : EP-QN5-3060A

Chuck size: 5, 30, 60, A

Normal (N) / Strong (S) / Pole size (50, 70)

<Ordering information>

- Sizes other than the standard sizes listed on page 31 are also available.
- The recommended maximum one-piece size is W1200 × L1500 mm. For other larger sizes, please contact us.
- Round chucks are also available.

When workpieces are hardened steel or special steel, they may be difficult to demount due to strong residual magnetism. In these cases, Model EP-D (P. 34) is recommended.

A guide for selection

General milling	Good holding conditions such as plate machining.	QN
Planomiller, horizontal M/C, use of straightening blocks, etc.	Poor holding conditions such as heavy duty cutting	QS

Selection of pole size □50 or □70

- The □70 size is superior in the absolute holding power and gap characteristic.
- The □50 size is recommended for relatively small and thin workpieces. (The plate thickness of magnetic saturation is 20 to 25 mm for □50 and 30 to 35 mm for □70.)

Relation between chuck models and holding power
Comparison of holding power of chucks of same size

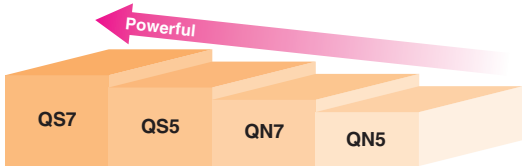

Holding power

□50 generates the max. holding power of 2.94 kN (300 kgf) or over per pole and □70 generates 5.88 kN (600 kgf) or over per pole.

(An example of calculation)
Max. holding power on whole attractive face of EP-QS5-4080A
2.94kN×60 (number of poles)=176.4kN {18000kgf}

EP-Q type holding power characteristic

1. Relation between workpiece thickness and holding power
Test piece held by 4 poles

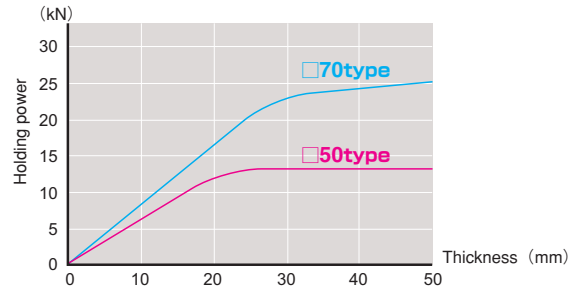

2. Relation between gap and holding power
Holding on whole face.

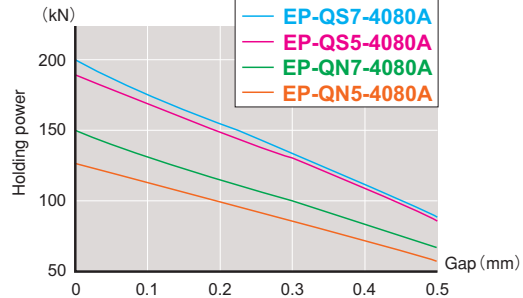

Model of special specification

Model with T-slots available

EP-QX50-S

For more information, please contact us.

EPS-P EP Chuck Master* Compact design for limited installation space.

EPS-P2100B-2

Model	EPS-P2100B	EPS-P2100B-2
Dimensions (W×H×D)	190 (7.48) × 165 (6.5) × 255 (10.0)	
Power source	Single-phase, 200 VAC 50/60 Hz	
Output capacity	10 VDC - 90 VDC pulse 100 A	
Output switchover	No switchover	2
Magnetizing time (approx.) · demagnetizing time (approx.)	1 sec.	3 sec.
Breaker capacity (ref.)	30A	
Mass	7.5kg (16.5)	7.6kg (16.7)

*The power cable must be larger than 3.5 mm² and less than 10 m.

Options

- ① Straightening block; for □50 and □70 (KT-Q)



Model	Type
□50 (1.96) × H28 (1.10)	Stationary
□70 (2.75) × H37 (1.45)	Movable

*The H dimension is the standard height.

- ② Separately installed feeder box
Recommended for applications that require frequent connector connection/disconnection.



ELECTROMAGNETIC CHUCKS
CHUCK CONTROLLERS
PERMANENT MAGNETIC CHUCKS
PERMANENT ELECTROMAGNETIC CHUCKS
BLOCKS FOR MC
VACUUM CHUCKS
PROMELTA* SYSTEM
SINE BAR CHUCKS
BLOCKS, HOLDERS, MINI CHUCKS
HOLDING TOOLS
MEASURING TOOL HOLDERS
MAGNETIC HOLDERS
MAGNETIC TOOLS

PERMANENT ELECTROMAGNETIC CHUCKS

Model EP-QD DEMAGNETIZING FUNCTION-EQUIPPED PERMANENT ELECTROMAGNETIC CHUCK FOR CUTTING

Weakness of checker board pattern type permanent electromagnetic chucks overcome!

Environmentally friendly



Minimal heat generation

Chuck controller required additionally



EP-QD7-3469

(Mounting size equivalent to 400 × 800)

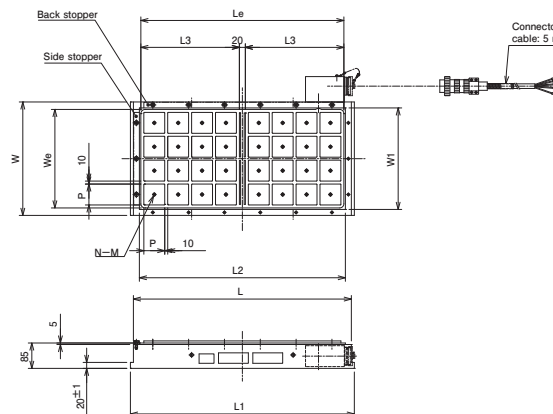

Holding power - thickness characteristic (4-pole holding, SS400 ground surface)

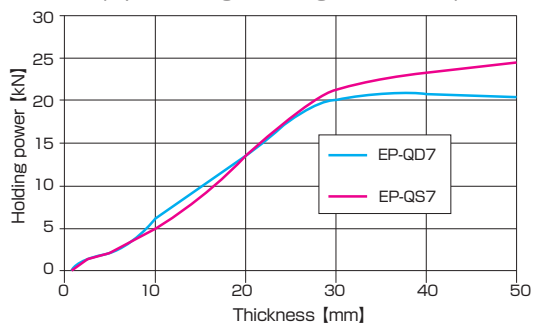

[Application]

Used for securing workpieces during cutting by milling machines, machining centers, etc.

[Features]

- An optimum combination of KANETEC's original magnetic pole construction and a construction dedicated to demagnetization has reduced residual holding power significantly.
- Hardened steel and special steel workpieces having large residual magnetism can be released easily. (Compared with conventional EP-Q)
- The optional straightening block (KT-Q70/Q70M) can be used. By mounting various blocks using tapped holes on the attractive face, various securing methods can be utilized according to machining operations.
- Can be used in wet operations.
- Special types having four poles minimum are available.

Model	Mounting Size	Work Face				Pole Dimensions				Mounting Face	Height	Tapped Hole on Attractive Face		Mass	Electro Chuck Master	
		W	W ₁	L	L ₂	W _e	L _e	No. of Poles	P			L ₂	N			M
EP-QD7-2669	300(11.8) × 800(31.5)	300(11.8)	260(10.2)	730(28.7)	690(27.1)	250(9.84)	680(26.7)	24	70(2.75)	330(12.9)	750(29.5)	85(3.34)	24(0.94)	10(0.39)	125kg/275 lb	EPS-D2100A
EP-QD7-3453	400(15.7) × 600(23.6)	380(14.9)	340(13.3)	570(22.4)	530(20.8)	330(12.9)	520(20.4)			250(9.84)	590(23.2)					
EP-QD7-3469	400(15.7) × 800(31.5)	540(21.2)	500(19.6)	730(28.7)	690(27.1)	680(26.7)	48	330(12.9)	750(29.5)	32	85(3.34)	32(1.25)	10(0.39)	160kg/352 lb	EPS-D2100A-2	
EP-QD7-5069	550(21.6) × 800(31.5)			48(1.88)	230kg/507 lb											

*The chuck controller and clamp parts are not included. *The KANETEC chucks work best when a KANETEC chuck controller is used.
 **Turning the permanent electromagnetic chucks on and off must be limited to once per several minutes. If on/off operations are repeated frequently, the chucks may be damaged by overheat.

Model EP-QL SUPER POWERFUL PERMANENT ELECTROMAGNETIC CHUCK FOR LONG WORKPIECE

A permanent electromagnetic chuck specialized in securing long workpieces! Powerfully holds workpieces without jigs!

Environmentally friendly

Chuck controller required additionally



EP-QL-24111A

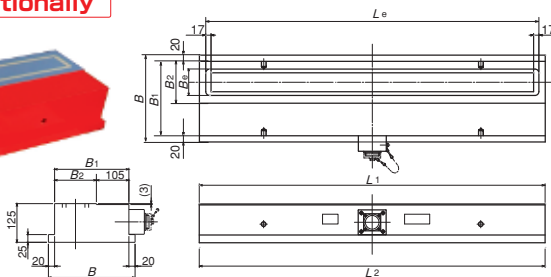

[Application]

Used to secure workpieces quickly and firmly during milling and machining of long workpieces such as railroad rails.

[Features]

- The employment of magnetic pole arrangement providing a wide attractive area enables it to attract and hold workpieces on the whole attractive face.
- A magnet for side-face attraction may be mounted to support securing of workpieces from sides.
- In place of a side-face attraction magnet, clamp parts may be used.

Model	Work Face			Mounting Face		Height	Mass	Electro Chuck Master
	B ₁	B ₂	B _e	L ₁	L _e			
EP-QL-24111A	240(9.44)	135(5.31)	85(3.34)	1115(43.8)	1074(42.2)	125(4.92)	270kg/595 lb	EPS-P2100B

*The chuck controller and clamp parts are not included. *The KANETEC chucks work best when a KANETEC chuck controller is used.
 **Turning the permanent electromagnetic chucks on and off must be limited to once per several minutes. If on/off operations are repeated frequently, the chucks may be damaged by overheat.

ELECTROMAGNETIC CHUCK CONTROLLERS: MAGNETIC CHUCKS ELECTROMAGNETIC CHUCKS PERMANENT ELECTROMAGNETIC CHUCKS BLOCKS FOR MC VACUUM CHUCKS PROMETA* SINE BAR CHUCKS BLOCKS/HOLDERS: MINI CHUCKS HOLDING TOOLS MEASURING TOOL HOLDERS: MAGNETIC HOLDERS MAGNETIC TOOLS

Model EP-QZ SUPER POWERFUL PERMANENT ELECTROMAGNETIC CHUCK FOR LONG WORKPIECE

Environmentally friendly

Chuck controller required additionally



EP-QZ8-1550A
An example of special fabrication

[Features]

- The gap characteristic is superior to that of the current Model EP-QN/ QS. These chucks are suitable for workpieces that have poor flatness and require large holding power.
- These chucks replace conventional hydraulic and mechanical clamping to reduce the setup time and improve productivity.
- The magnetic poles are arranged according to shapes and length of workpieces such as rails. Securing blocks specially designed according to workpiece shapes are also available.
- A type with a separator made of brass is also available.

Model	Max. Holding Power per Pole	Pole Size	No. of Poles	Features	Electro Chuck Master
EP-QZ8-15100A	□75 (□2.95) 750kgf	□75 (□2.95)	5	Single type	EPS-P2100B
EP-QZW-30100A	□50 (□1.96) 300kgf	□75 (2.95) + □50 (1.96)	10 (□75) + 14 (□50)	Double type	EPS-P2100B-2

※The chuck controller and clamp parts are not included. ※The KANETEC chucks work best when a KANETEC chuck controller is used.

※Turning the permanent electromagnetic chucks on and off must be limited to once per several minutes. If on/off operations are repeated frequently, the chucks may be damaged by overheat.

Model EP-D DEMAGNETIZING FUNCTION-EQUIPPED PERMANENT ELECTROMAGNETIC CHUCK FOR CUTTING

Strong holding power and good release performance realized!

Environmentally friendly

Power saving

Minimal heat generation

Chuck controller required additionally



EP-D3060

[Application]

Used for securing workpieces during cutting by milling machines, machining centers, etc.

[Features]

- A coil dedicated to demagnetization has significantly improved the workpiece release performance when the chuck is turned off.
- The magnetic pole arrangement to concentrate magnetism on the workpiece provides strong holding power.
- Hardened steel and special steel workpieces having large residual magnetism can be released quicker than the conventional chucks.
- Electricity is used only when mounting and demounting workpieces, thus minimal heat is generated and electricity is saved.
- Can be used in wet operations.

Model	Work Face		Dimensions				Mounting Face	Mass	Electro Chuck Master
	W	L	W _e	L _e	W ₁	W ₂	L ₁		
EP-D 3060	304 (11.9)	618 (24.3)	264 (10.3)	558 (21.9)	240 (9.44)	232 (9.13)	638 (25.1)	110kg/242 lb	EPS-D2100A
EP-D 4080	404 (15.9)	786 (30.9)	364 (14.3)	726 (28.5)	340 (13.3)	332 (13.0)	806 (31.7)	185kg/407 lb	
EP-D50100	504 (19.8)	1038 (40.8)	464 (18.2)	978 (38.5)	440 (17.3)	432 (17.0)	1058 (41.6)	305kg/672 lb	EPS-D2100A-2
EP-D60100	604 (23.7)		564 (22.2)		240 (9.44) × 2	232 (9.13) × 2		365kg/804 lb	

※Turning the permanent electromagnetic chucks on and off must be limited to once per several minutes. If on/off operations are repeated frequently, the chucks may be damaged by overheat.

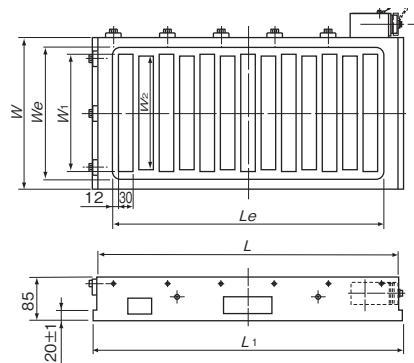

Comparison of holding power

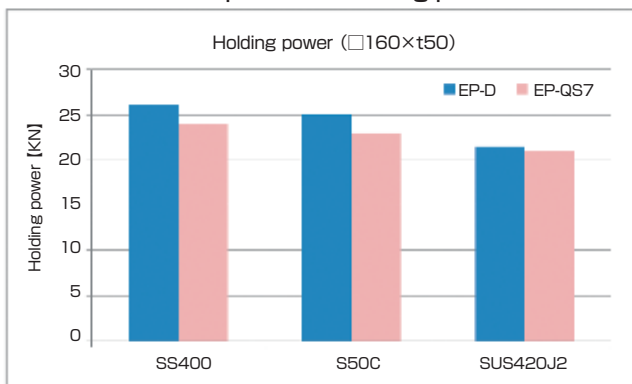

Comparison of residual holding power

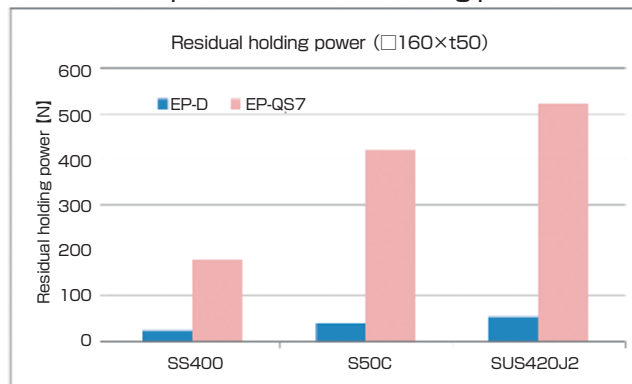

ELECTROMAGNETIC CHUCKS
 CHUCK CONTROLLERS
 PERMANENT ELECTROMAGNETIC CHUCKS
 BLOCKS FOR MC
 VACUUM CHUCKS
 PROMELTA* SYSTEM
 SINE BAR CHUCKS
 BLOCKS, HOLDERS, MINI CHUCKS
 HOLDING TOOLS
 MEASURING TOOL HOLDERS
 MAGNETIC HOLDERS
 MAGNETIC TOOLS

PERMANENT ELECTROMAGNETIC CHUCKS

Model EP-DV POWERFUL PERMANENT ELECTROMAGNETIC CHUCK WITH VACUUM FUNCTION

Hybrid chuck to handle diversified materials!

[Application]

Permanent electromagnetic chucks for cutting equipped with a grid-seal type vacuum chuck function added to hold workpieces during cutting and grinding of magnetic and nonmagnetic workpieces.

[Features]

- The strong holding power makes these chucks suitable for cutting of magnetic materials.
- Electricity is used only when mounting and demounting workpieces, thus minimal heat is generated and electricity is saved.
- Since these chucks have a construction dedicated to demagnetization, they have good workpiece release performance when they are turned off.
- The vacuum chuck can be set to a desired area by use of seal rubber according to workpieces.
- When machining nonmagnetic workpieces, the permanent electromagnetic feature can be utilized to hold magnetic substances around them to secure them firmly.



Chuck controller and vacuum system required additionally



EP-DV3060

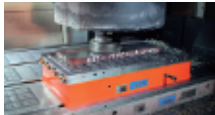
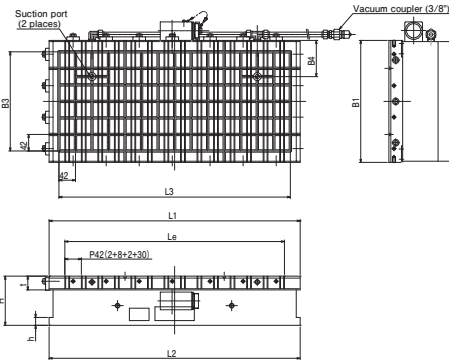

An example of milling by utilizing the permanent electromagnetic feature



An example of grinding of brass by utilizing the permanent electromagnetic feature

Model	Nominal Size	Work Face					Pole Pitch	Mounting Face			Height	Grid Pitch	Effective Area B ₃ × L ₃	Mass	Electro Chuck Master	Applicable Vacuum System	
		B ₁	L ₁	L _e	t	B ₄		B ₂	L ₂	h							
EP-DV 3060	300 (11.8) × 600 (23.6)	310 (12.2)	638 (25.1)	558 (21.9)		92 (3.62)	42 (2+8+2+30) (1.65)	304 (11.9)	638 (25.1)		125 (4.92)	42 (1.65) × 42 (1.65)	252 (9.9) × 588 (23.1)	170kg/ 374lb	EPS-D2100A	VPU-EG VPU-E10 VPU-D20	
EP-DV 4080	400 (15.7) × 800 (31.5)	410 (16.1)	806 (31.7)	726 (28.5)	35 (1.37)	79 (3.11)		404 (15.9)	806 (31.7)	20 (0.78)			378 (14.8) × 756 (29.7)				280kg/ 617lb
EP-DV50100	500 (19.6) × 1000 (39.4)	510 (20.0)	1058 (41.6)	978 (38.5)		87 (3.42)		504 (19.8)	1058 (41.6)				462 (18.1) × 1008 (39.6)				450kg/ 992lb

※The chuck controller, vacuum system and clamp parts are not included. ※The KANETEC chucks work best when a KANETEC chuck controller is used.
 ※Turning the permanent electromagnetic chucks on and off must be limited to once per several minutes. If on/off operations are repeated frequently, the chucks may be damaged by overheat.

Model EP-DWM POWERFUL PERMANENT ELECTROMAGNETIC CHUCK FOR HEAVY DUTY CUTTING

Chuck controller required additionally

Strong magnetic force & good release performance & high water-tightness!



EP-DWM3060

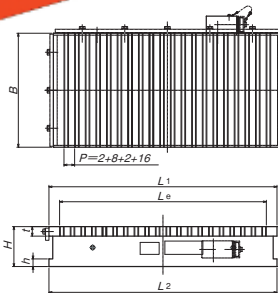

[Application]

Suitable for such precision machining of relatively large load as heavy duty grinding and cutting and for securing workpieces having steps such as linear motion guides.

[Features]

- Capable of holding relatively small workpieces, workpieces having a small attractive area and concave workpieces.
- The addition of a construction dedicated to demagnetization has improved the workpiece release performance when the chuck is turned off.
- Hardened steel and special steel workpieces having large residual magnetism can be released quickly.
- Electricity is supplied momentarily for mounting and demounting workpieces, thus minimal heat is generated and electricity is saved.
- The chucks can be used in wet operations and have improved water-tightness.
- A resin-bonded structural face plate having little environmental burden is employed.

Model	Work Face				Pole Pitch	Mounting Face		Height	Mass	Electro Chuck Master
	B	L ₁	L _e	t		L ₂	h			
EP-DWM2050	200 (7.87)	490 (19.2)	432 (17.0)		25 (0.98)	490 (19.2)	20 (0.78)	105 (4.13)	70kg/154 lb	EPS-D2100A
EP-DWM3060	300 (11.8)	600 (23.6)	544 (21.4)			600 (23.6)			125kg/275 lb	
EP-DWM4080	400 (15.7)	820 (32.2)	768 (30.2)			820 (32.2)			230kg/507 lb	

※The chuck controller, vacuum system and clamp parts are not included. ※The KANETEC chucks work best when a KANETEC chuck controller is used.
 ※Turning the permanent electromagnetic chucks on and off must be limited to once per several minutes. If on/off operations are repeated frequently, the chucks may be damaged by overheat.

Model EPS-D CHUCK MASTER* DEDICATED TO DEMAGNETIZING FUNCTION-EQUIPPED PERMANENT ELECTROMAGNETIC CHUCK



EPS-D2100A

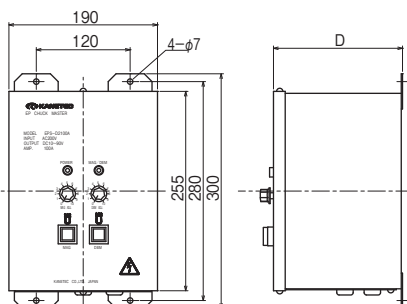

[Application]

A chuck controller dedicated to permanent electromagnetic chucks equipped with a demagnetizing function.

Model	EPS-P2100A	EPS-P2100A-2
Dimensions (W × H × D)	190 (7.48) × 165 (6.5) × 255 (10.0)	190 (7.48) × 200 (7.87) × 255 (10.0)
Power Source	Single-phase, 200 VAC 50/60 Hz	
Output capacity	10 VDC - 90 VDC pulse 100 A	
Output switchover	No switchover	2
Magnetizing time (approx.) · demagnetizing time (approx.)	1 sec./4 sec.	3 sec./6 sec.
Breaker capacity (ref.)	30A	
Mass	7.5kg (16.5)	8kg (17.6)

ELECTROMAGNETIC CHUCK CONTROLLERS: PERMANENT ELECTROMAGNETIC CHUCKS
 BLOCKS FOR MC
 VACUUM CHUCKS
 PROMETA*
 SINE BAR
 BLOCKS, HOLDERS, MINI CHUCKS
 HOLDING TOOLS
 MEASURING TOOL HOLDERS
 MAGNETIC HOLDERS
 MAGNETIC TOOLS

Model **EPT/EPT-LW** PERMANENT ELECTROMAGNETIC CHUCK (STANDARD/LOW MAGNETIC FORCE CONTROL)

Environmentally friendly



Minimal heat generation

Chuck controller required additionally

[Application]

Suitable for high precision grinding and slicing.

[Features]

- Since electricity is supplied momentarily only to control the magnetomotive force when mounting/demounting a workpiece, little heat is generated internally to enable highly precise machining.
- Since electricity needs not be supplied continuously even while holding a workpiece, the running cost is very low.
- Since the holding power is maintained by the permanent magnet, safety is secured in the event of power failure and cable breakage.
- A resin-bonded structural face plate having little environmental burden is employed.

About EPT-LW

Model EPT-LW is equipped with a low magnetic force (weak attraction) control function that is difficult with conventional permanent electromagnetic chucks and therefore facilitates strain relieving and workpiece positioning at the same level as electromagnetic chucks. (When the low magnetic force control is active, the power is supplied continuously.)

Please note that a dedicated Chuck Master (Model EPH-LW) (see page 38) needs to be used together.

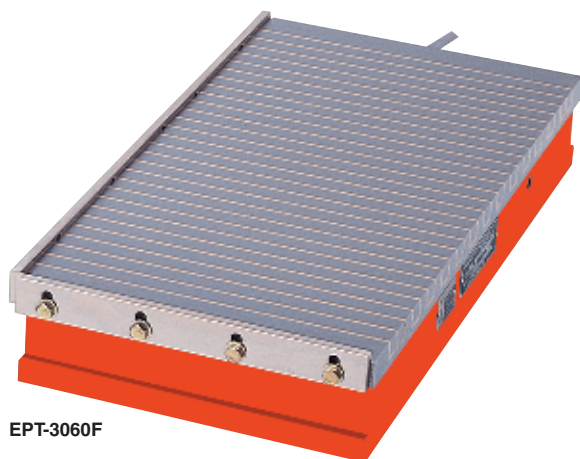

EPT-3060F

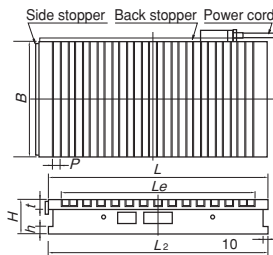

NOTE: The L₂ dimension has not been machined together with L and therefore, there may be some variation.

Model		Nominal Size	Work Face				Pole Pitch P	Mounting Face		Height H	Voltage		Current		Power Cord	Mass	Electro Chuck Master	
Standard	Low mag. force control		B	L	Le	t		L ₂	h		Standard	Low mag. force control	Standard	Low mag. force control			Standard	Low mag. force control
EPT- 1530F	EPT-LW 1530F	150(5.90) × 300(11.8)	300	240			300					1.91A	0.80A		24kg/ 52 lb			
EPT- 1535F	EPT-LW 1535F	150(5.90) × 350(13.7)	150	350			350					2.43A	0.93A	2m (78.7)	28kg/ 61 lb			
EPT- 1545F	EPT-LW 1545F	150(5.90) × 450(17.7)		450	380	20.5 (0.80)	450		80 (3.15)			2.64A	1.17A		36kg/ 79 lb		EPH-LW205B EPH-LWE205B	
EPT- 2050F	EPT-LW 2050F	200(7.87) × 500(19.6)	200	500	436		500					5.88A	3.31A		53kg/ 116 lb			
EPT- 2060F	EPT-LW 2060F	200(7.87) × 600(23.6)		600	548		600	20 (0.78)		90 VDC	180 VDC	7.87A	3.82A	3m (118)	65kg/ 143 lb		EPS-215B	
EPT- 3060F	EPT-LW 3060F	300(11.8) × 600(23.6)	300	600	529		600					6.14A	2.55A		140kg/ 308 lb			
EPT- 4080F	EPT-LW 4080F	400(15.7) × 800(31.5)		800	724		800					11.0A	6.59A		211kg/ 465 lb			
EPT-40100F	EPT-LW40100F	400(15.7) × 1000(39.4)	400	1000	919	25.0 (0.98)	1000		100 (3.93)			12.5A	6.45A	5m (196)	265kg/ 584 lb		EPH-LWE210B	
EPT- 5080F	EPT-LW 5080F	500(19.6) × 800(31.5)		800	724		800					9.01A	5.41A		330kg/ 727 lb			
EPT-50100F	EPT-LW50100F	500(19.6) × 1000(39.4)		1000	919		1000					11.7A	6.00A					

※The chuck controller and clamp parts are not included. ※The KANETEC chucks work best when a KANETEC chuck controller is used.
 ※Turning the permanent electromagnetic chucks on and off must be limited to once per several minutes. If on/off operations are repeated frequently, the chucks may be damaged by overheat.

Model **EPT-H** POWERFUL PERMANENT ELECTROMAGNETIC CHUCK

Environmentally friendly



Minimal heat generation

Chuck controller required additionally

[Application]

Suitable for high precision grinding and slicing.

[Features]

- Compared with the standard type (EPT), these chucks generate a larger magnetic force and therefore are capable of securing workpieces firmly during grinding of large machining load.
- A resin-bonded structural face plate having little environmental burden is employed.

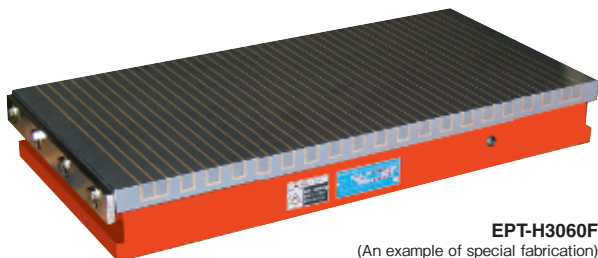

EPT-H3060F
(An example of special fabrication)

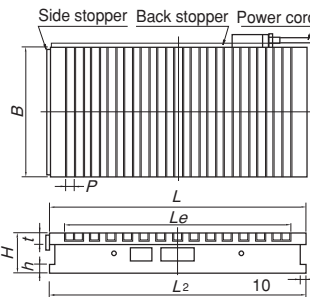

NOTE: The L₂ dimension has not been machined together with L and therefore, there may be some variation.

Model		Nominal Size	Work Face				Pole Pitch P	Mounting Face		Height H	Voltage	Power Cord	Mass	Electro Chuck Master
			B	L	Le	t		L ₂	h					
EPT-H1530F		150(5.90) × 300(11.8)	150(5.90)	300(11.8)	240(9.44)	30 (1.18)	300(11.8)	20 (0.78)	100 (3.93)	180 VDC	2m(78.7)	30kg/ 66.1 lb	EPS-W215B	
EPT-H2050F		200(7.87) × 500(19.6)	200(7.87)	500(19.6)	436(17.1)		500(19.6)				83kg/ 183 lb			
EPT-H3060F		300(11.8) × 600(23.6)	300(11.8)	600(23.6)	529(20.8)		600(23.6)				142kg/ 313 lb			
EPT-H4080F		400(15.7) × 800(31.5)	400(15.7)	800(31.5)	724(28.5)	800(31.5)	215kg/ 474 lb							
EPT-H50100F		500(19.6) × 1000(39.4)	500(19.6)	1000(39.4)	919(36.1)	1000(39.4)	335kg/ 738 lb							

※The chuck controller and clamp parts are not included. ※The KANETEC chucks work best when a KANETEC chuck controller is used.
 ※Turning the permanent electromagnetic chucks on and off must be limited to once per several minutes. If on/off operations are repeated frequently, the chucks may be damaged by overheat.

ELECTROMAGNETIC CHUCKS
 CHUCK CONTROLLERS
 PERMANENT ELECTROMAGNETIC CHUCKS
 BLOCKS FOR MC
 VACUUM CHUCKS
 PROMELTA* SYSTEM
 SINE BAR CHUCKS
 BLOCKS, HOLDERS, MINI CHUCKS
 HOLDING TOOLS
 MEASURING TOOL HOLDERS
 MAGNETIC HOLDERS
 MAGNETIC TOOLS

PERMANENT ELECTROMAGNETIC CHUCKS

Model EPTW PERMANENT ELECTROMAGNETIC MICROPITCH CHUCK

Chuck controller required additionally



Minimal heat generation



EPTW-1530

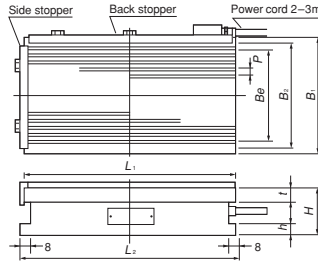

[Application]

Suitable for precision grinding on grinders and for holding thin and thick workpieces having a large area.

[Features]

- Thanks to finer pole pitches on the chuck work face, these chucks hold thin and wide workpieces firmly.
- Since electricity is supplied momentarily only to control the magnetomotive force when mounting/demounting a workpiece, little heat is generated internally to maintain accuracy.
- Since electricity needs not be supplied continuously even while holding a workpiece, the running cost is very low.
- Since the holding power is maintained in the event of power failure and cable breakage, safety is secured.

[mm (in)]

Model	Nominal Size	Work Face				Pole Pitch	Mounting Face			Height	Voltage	Power Cord	Mass	Electro Chuck Master
		B ₁	L ₁	t	B _e		B ₂	L ₂	h					
EPTW-1530	150 (5.90) × 300 (11.8)	150 (5.90)	300 (11.8)	20	125 (4.92)	4 (0.8+3.2) 0.15 (0.03+0.12)	148 (5.82)	300 (11.8)	18	95	2m (78.7)	29kg/ 63 lb	EPS-215B	
EPTW-1545	150 (5.90) × 450 (17.7)		450 (17.7)	(0.78)			450 (17.7)	198 (7.79)	400 (15.7)			180 (7.0)		44kg/ 97 lb
EPTW-2040	200 (7.87) × 400 (15.7)	200 (7.87)	400 (15.7)	25 (0.98)	173 (6.81)	248 (9.76)	400 (15.7)	20 (0.78)	120 (4.72)	3m (118)	65kg/ 143 lb			
EPTW-2050	200 (7.87) × 500 (19.6)		500 (19.6)				217 (8.54)				500 (19.6)	298 (11.7)		600 (23.6)
EPTW-2560	250 (9.84) × 600 (23.6)	250 (9.84)	600 (23.6)	269 (10.5)	298 (11.7)	600 (23.6)	123kg/ 271 lb							
EPTW-3060	300 (11.8) × 600 (23.6)	300 (11.8)	600 (23.6)	269 (10.5)	298 (11.7)	600 (23.6)	147kg/ 324 lb							

※ The chuck controller and clamp parts are not included. ※ The KANETEC chucks work best when a KANETEC chuck controller is used.

※ Turning the permanent electromagnetic chucks on and off must be limited to once per several minutes. If on/off operations are repeated frequently, the chucks may be damaged by overheat.

Model EPTW-N PERMANENT ELECTROMAGNETIC MICROPITCH CHUCK



Minimal heat generation

Environmentally friendly

Chuck controller required additionally



EPTW-N2040

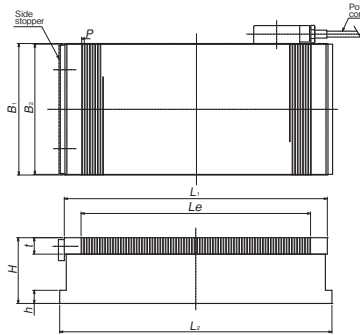

[Application]

Suitable for grinding of thin and small workpieces.

[Features]

- Generates strong holding power on workpieces of □25 mm and larger.
- Instead of the conventional magnetic pole longitudinal patterns, the transverse magnetic pole patterns are used.
- A resin-bonded structural face plate having little environmental burden is employed.

[mm (in)]

Model	Nominal Size	Work Face				Pole Pitch	Mounting Face			Height	Voltage	Power Cord	Mass	Electro Chuck Master
		B ₁	L ₁	t	L _e		B ₂	L ₂	h					
EPTW-N1530	150 (5.90) × 300 (11.8)	150 (5.90)	300 (11.8)	261 (10.2)	25 (0.98)	4 (1+3) 0.15 (0.04+0.11)	148 (5.82)	314 (12.3)	100 (3.93)	180 VDC	2m (78.7)	30kg/ 66 lb	EPS-W215B	
EPTW-N1545	150 (5.90) × 450 (17.7)		450 (17.7)	397 (15.6)			450 (17.7)	198 (7.79)	464 (18.2)			110 (4.33)		45kg/ 99 lb
EPTW-N2040	200 (7.87) × 400 (15.7)	200 (7.87)	400 (15.7)	349 (13.7)	549 (21.6)	246 (9.68)	414 (16.2)	20 (0.78)	110 (4.33)	3m (118)	52kg/ 114 lb			
EPTW-N2050	200 (7.87) × 500 (19.6)		500 (19.6)	449 (17.6)			514 (20.2)				296 (11.6)	614 (24.1)		65kg/ 143 lb
EPTW-N2560	250 (9.84) × 600 (23.6)	250 (9.84)	600 (23.6)	549 (21.6)	296 (11.6)	614 (24.1)	107kg/ 235 lb							
EPTW-N3060	300 (11.8) × 600 (23.6)	300 (11.8)	600 (23.6)	549 (21.6)	296 (11.6)	614 (24.1)	128kg/ 282 lb							

※ The chuck controller and clamp parts are not included. ※ The KANETEC chucks work best when a KANETEC chuck controller is used.

※ Turning the permanent electromagnetic chucks on and off must be limited to once per several minutes. If on/off operations are repeated frequently, the chucks may be damaged by overheat.

Model EPZ-U TILT TYPE PERMANENT ELECTROMAGNETIC CHUCK



Minimal heat generation

Environmentally friendly

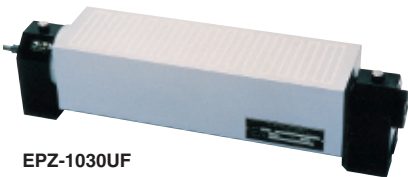

EPZ-1030UF

Chuck controller required additionally

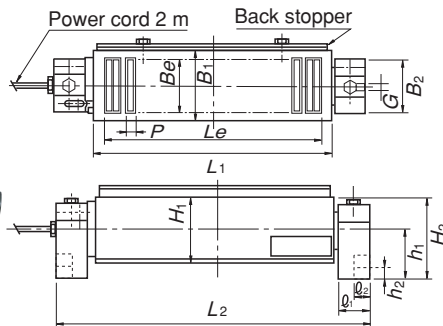

[Application]

Suitable for angle grinding on grinders. Easy to install.

[Features]

- The rotary shaft with scale facilitates angle setting. (An angle can be set as desired in a range of 90° forward and 90° backward.)
- Since electricity is supplied momentarily only to control the magnetomotive force when mounting/demounting a workpiece, little heat is generated internally to enable highly precise machining.
- Since electricity needs not be supplied continuously even while holding a workpiece, the running cost is very low.
- Since the holding power is maintained in the event of power failure and cable breakage, safety is secured.

[mm (in)]

Model	Nominal Size	Work Face				Pole Pitch	Tilt Base				Length	Height	Voltage	Mass	Electro Chuck Master	
		B ₁	L ₁	B _e	L _e		H ₁	B ₂	ℓ ₁	ℓ ₂						G
EPZ-1025UF	100 (3.93) × 250 (9.84)	100 (3.93)	250 (9.84)	78 (3.07)	211 (8.30)	100 (3.93)	50 (1.96)	29 (1.14)	14 (0.55)	80 (3.15)	15 (0.59)	368 (14.4)	130 (5.11)	90 VDC	22kg/ 48 lb	EPS-215B
EPZ-1030UF	100 (3.93) × 300 (11.8)		300 (11.8)	96 (3.78)	255 (10.0)					14 (2+12) 0.55 (0.07+0.47)	95 (3.74)				418 (16.4)	
EPZ-1230UF	120 (4.72) × 300 (11.8)	120 (4.72)	300 (11.8)	240 (9.44)	408 (16.0)	100 (3.93)	50 (1.96)	29 (1.14)	14 (0.55)	95 (3.74)	15 (0.59)	568 (22.3)	145 (5.70)	90 VDC	30kg/ 66 lb	
EPZ-1530UF	150 (5.90) × 300 (11.8)		450 (17.7)	120 (4.72)						408 (16.0)	95 (3.74)				15 (0.59)	
EPZ-1545UF	150 (5.90) × 450 (17.7)	150 (5.90)	450 (17.7)	120 (4.72)	408 (16.0)	100 (3.93)	50 (1.96)	29 (1.14)	14 (0.55)	95 (3.74)	15 (0.59)	568 (22.3)	145 (5.70)	90 VDC	37kg/ 81 lb	
EPZ-1545UF	150 (5.90) × 450 (17.7)		450 (17.7)	120 (4.72)						408 (16.0)	95 (3.74)				15 (0.59)	

※ The chuck controller and clamp parts are not included. ※ The KANETEC chucks work best when a KANETEC chuck controller is used.

※ Turning the permanent electromagnetic chucks on and off must be limited to once per several minutes. If on/off operations are repeated frequently, the chucks may be damaged by overheat.

Model **EPS** EP CHUCK MASTER*

Control unit for permanent electromagnetic chucks

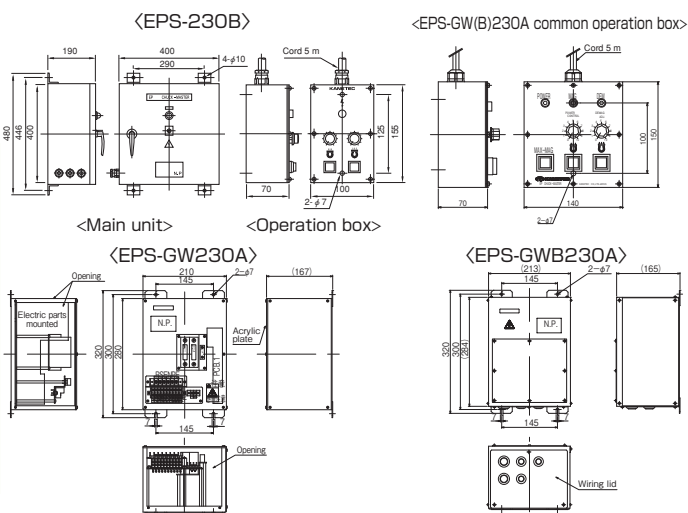

[Application]

Rectifies an input from an AC power source to DC and momentarily outputs exciting current to permanent electromagnetic chucks. The automatic demagnetization circuit is activated to reduce residual magnetism of permanent electromagnetic chucks.

[Features]

- The EP Chuck Master* is dedicated to permanent electromagnetic chucks and can be used for EPT, EPT-H, EPTW and EPZ-U.
- The microcomputer control ensures very effective automatic demagnetization.
- The holding power is adjustable.
- Model EPS-GW (B) is of external operation type.

<Major features>

- EPS-GW is installed inside the machine panel and EPS-GWB is installed outside the panel and both of them are equipped with a remote operation box.
- Compared with the conventional type, the volume has been reduced to about a third.
- The workability and operability such as wiring, fuse replacement, switchover of voltage between 200 VAC and 220 VAC and output voltage/demagnetizing time adjustment have been improved.

General type

Model	Power Source	Rated Output		Dimensions			Mounting Dimensions			Mass	Operation box			
		Voltage	Current	Width	Depth	Height	Width	Height	Hole		Width	Depth	Height	Cord
EPS-215B	Single-phase 200 VAC (50/60Hz)	20- 90 VDC	15A	180 (7.08)	130 (5.11)	250 (9.84)	120 (4.72)	275 (10.8)	4-φ 7 (0.27)	4.7kg/10.3 lb	—	—	—	—
EPS-230B			30A	400 (15.7)	190 (7.48)	400 (15.7)	290 (11.4)	446 (17.5)	4-φ 10 (0.39)	18.3kg/40.3 lb	100 (3.93)	70 (2.75)	155 (6.10)	5m (196)
EPS-W215B	Single-phase 200/220 VAC (50/60Hz)	40-180 VDC	15A	180 (7.08)	130 (5.11)	250 (9.84)	120 (4.72)	275 (10.8)	4-φ 7 (0.27)	4.7kg/10.3 lb	—	—	—	—
EPS-GW230A			30A	210 (8.26)	167 (6.57)	280 (11.0)	145 (5.70)	300 (11.8)	2-φ 7 (0.27) (2 - width 7)	7.0kg/15.4 lb	140 (5.51)	70 (2.75)	150 (5.90)	5m (196)
EPS-GWB230A			30A	213 (8.38)	165 (6.49)	284 (11.1)	145 (5.70)	300 (11.8)	2-φ 7 (0.27) (2 - width 7)	9.0kg/19.8 lb	140 (5.51)	70 (2.75)	150 (5.90)	5m (196)

*The applicable models are EPT, EPT-H, EPTW and EPZ-U only. ※EPS-GW (B) 230A is used as a control unit for the connection of same models or specially ordered large chucks.

Model **EPH-LW** NON-CONTACT TYPE EP CHUCK MASTER*

Low magnetic force control function

[Application]

The use of the low magnetic force control function enables straightening operations as with electromagnetic chucks. The use of the low magnetic force control function facilitates positioning of workpieces. (The low magnetic force control requires electricity to be supplied continuously. When used with the low magnetic force control function activated for long hours, accuracy change due to heat generated in the permanent electromagnetic chuck itself may slightly affect the machining accuracy.)

[Features]

These Chuck Masters enable it to control the low magnetic force (weak holding power), which is difficult with permanent electromagnetic chucks. When a conventional permanent electromagnetic chuck is used, it is necessary to turn it off once and after lowering the magnetizing voltage, turn it on again in order to set a low magnetic force for straightening grinding operations. These Chuck Masters have a control function by which the power can be applied continuously only in the low output region, which makes it possible to finely and continuously adjust the low magnetic force region as with electromagnetic chucks. They offer a possibility of straightening grinding with permanent electromagnetic chucks. Workpieces can also be positioned smoothly with the low magnetic force control.

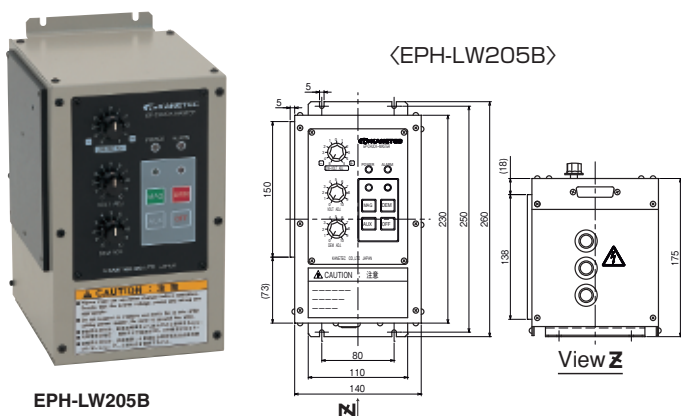

Model	Power Source	Rated Output		Dimensions			Mass	
		Voltage	Current	Width	Height	Depth	Chuck Master	Operation box
EPH-LW205B	Single-phase 200 VAC 50/60Hz	Permanent electromagnetic: 0 - 180 VDC (2 sec.) Low magnetic force: ±0 - 60 VDC (continuous)	5A	140 (+ 5)	5.51 (+0.19)	230 (9.05)	175 (6.89)	Operated from main unit panel
EPH-LWE205B			10A	220 (+30)	8.66 (+1.18)	250 (9.84)	—	Approx. 0.6kg/1.3 lb
EPH-LWE210B		10A	—	—	—	—	—	Approx. 6.0kg/13.2 lb

*Non-contact type Chuck Masters (with low magnetic force control) for permanent electromagnetic chucks (180 VDC version). ※The low magnetic force control is possible when used in combination with the permanent electromagnetic chuck Model EPT-LW. ※Three types; rated output of 180 VDC-5A, 180 VDC-5A (with operation box) and 180 VDC-10A (with operation box) are available.

ELECTROMAGNETIC CHUCKS
CHUCK CONTROLLERS
PERMANENT ELECTROMAGNETIC CHUCKS
BLOCKS FOR MC
VACUUM CHUCKS
PROMELTA* SYSTEM
SINE BAR CHUCKS
BLOCKS, HOLDERS, MINI CHUCKS
HOLDING TOOLS
MEASURING TOOL HOLDERS
MAGNETIC HOLDERS
MAGNETIC TOOLS

Model **EPC** ROUND PERMANENT ELECTROMAGNETIC CHUCK

Revolutionary permanent electromagnetick chuck!
Magnetic force adjustable!

Patented

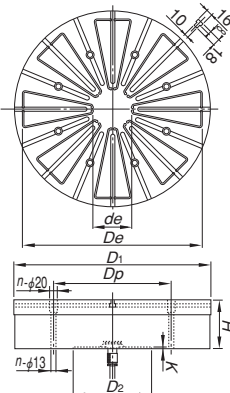
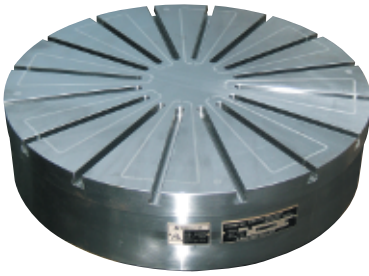

[Application]

Suitable for machining of ring-shaped workpieces such as bearings while rotating them on lathes, turning machines, cylindrical grinders and rotary grinders.

[Features]

- When used in combination with a dedicated controller equipped with a magnetic force adjust function, the magnetic force can be adjusted between strong and weak.
- Since internal heat generation and thermal distortion are minimal, highly precise machining is possible.
- Can be used in wet operations.
- These chucks are provided with T-grooves to make them suitable for various workpieces.

EPC-50AS-S
<An example of special fabrication>

Chuck controller required additionally

A size φ 1200 and larger is also available. [mm (in)]

Model	Nominal Size	Work Face			No. of Poles	Mounting Face			Height	Voltage	Current	Mass	Electro Chuck Master	
		D ₁	D _e	d _e		D ₂	K	n						D _p
EPC- 50AST	500 (19.6)	500 (19.6)	460 (18.1)	100 (3.93)	8	200 (7.87)	5 (0.19)	8	300 (11.8)	125 (4.92)	180 VDC	27A	Approx. 140kg/ 308 lb	EPS-RW230A
EPC- 70AST	700 (27.5)	700 (27.5)	656 (25.8)	120 (4.72)								400 (15.7)	12	500 (19.6)
EPC- 90AST	900 (35.4)	900 (35.4)	850 (33.4)	200 (7.87)	500 (19.6)	18	1000 (39.4)	150 (5.90)	45A	Approx. 600kg/ 1323 lb		EPS-RW275A		
EPC-120AST	1200 (47.2)	1200 (47.2)	1150 (45.2)	300 (11.8)	650 (25.5)				6 (0.23)	18			1000 (39.4)	150 (5.90)

※ The chuck controller is not included.
 ※ The slip ring (carbon brush included) is optional. The brush holder support bar for the slip ring should be provided by the user.
 ※ Turning the permanent electromagnetic chucks on and off must be limited to once per several minutes. If on/off operations are repeated frequently, the chucks may be damaged by overheat.

※ Dedicated operation box (Size 140×70×155, cord 5 m) included.

Model	Power Source	Output		Dimensions			Mass
		Voltage	Current	Width	Height	Depth	
EPS-RW230A	200 VAC (50/60Hz)	180 VDC (16 steps)	30A	400 (15.7)	480 (18.8)	190 (7.48)	Approx. 15kg/ 33.0 lb
EPS-RW250A			50A		725 (28.5)	250 (9.84)	Approx. 35kg/ 77.1 lb
EPS-RW275A			75A				

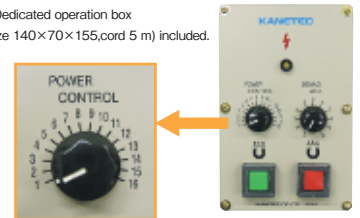

Model **EPC-Z** POWERFUL ROUND PERMANENT ELECTROMAGNETIC CHUCK

Construction machinery / Ship building / Nuclear power plant / Wind power generation
Highly precise machining of ring-shaped workpiece such as bearings!



Chuck controller required additionally

[Application]

Suitable for machining of ring-shaped workpieces such as bearings while rotating them on lathes and cylindrical grinders.

[Features]

- The employment of a magnetic pole construction suitable for cutting has increased the holding power. Suitable for cutting operations where large load is applied.
- The rectangular magnetic poles provide consistent holding power regardless of workpiece sizes.
- By using included blocks with T-grooves and adapter blocks, various workpieces, small and large, can be held.
- By mounting blocks, workpieces can be machined while being lifted. This feature enables it to machine workpieces from any direction. Also removal of chips and maintenance are easy.

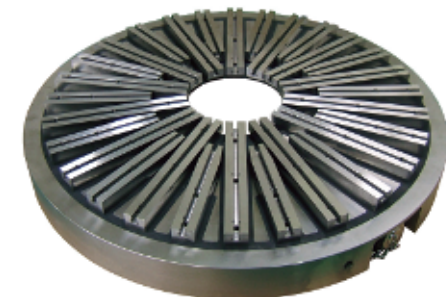

EPC-Z90

<Chuck controller>

Model	Dimensions	No. of Poles	Applicable Workpiece Diameter		Mass	Electro Chuck Master
			Min. dia.	Max. dia.		
EPC-Z60	φ 640 (25.1) × 90 (3.54)	14	250 (9.84)	600 (23.6)	170kg/ 374 lb	EPS-PZ2100A-2
EPC-Z90	φ 950 (37.4) × 90 (3.54)			900 (35.4)	410kg/ 904 lb	EPS-PZ2100A-4
EPC-Z120	φ 1250 (49.2) × 90 (3.54)	28 (14+14)		1200 (47.2)	725kg/ 1598 lb	EPS-PZ2100A-6
EPC-Z150	φ 1550 (61.0) × 110 (4.33)	44 (22+22)	500 (19.6)	1500 (59.0)	1280kg/ 2822 lb	EPS-PZ2100A-8
EPC-Z180	φ 1850 (72.8) × 110 (4.33)	43	800 (31.5)	1800 (70.8)	1580kg/ 3483 lb	EPS-PZ2100A-10
EPC-Z200	φ 2050 (80.7) × 110 (4.33)	50	1000 (39.4)	2000 (78.7)	1800kg/ 3969 lb	EPS-PZ2100A-10

※ The chuck controller is not included.
 ※ The power is supplied through the metal connector (with cable connection confirmation signal) on the side of the chuck.

Model	Power Source	Output		Breaker Capacity	Dimensions			Mass
		Voltage	Current		Width	Height	Depth	
EPS-PZ2100A-2	200 VAC (50 / 60Hz) 1 φ	90 VDC × 2 times switching	Pulse 100 A (per switching)	30A	450 (17.7)	450 (17.7)	200 (7.87)	15kg/ 33.0 lb
EPS-PZ2100A-4					250 (9.84)	750 (29.5)	250 (9.84)	35kg/ 77.1 lb
EPS-PZ2100A-6								40kg/ 88.2 lb
EPS-PZ2100A-8								50kg/ 110 lb
EPS-PZ2100A-10								80kg/ 176 lb

ELECTROMAGNETIC CHUCK CONTROLLERS PERMANENT ELECTROMAGNETIC CHUCKS EQUIPMENT FOR MC BLOCKS VACUUM CHUCKS PROMELTA* SINE BAR CHUCKS BLOCKS, HOLDERS, MINI CHUCKS HOLDING TOOLS MEASURING TOOL HOLDERS MAGNETIC HOLDERS MAGNETIC TOOLS