

Model KVR VACUUM CHUCK

Vacuum system required additionally

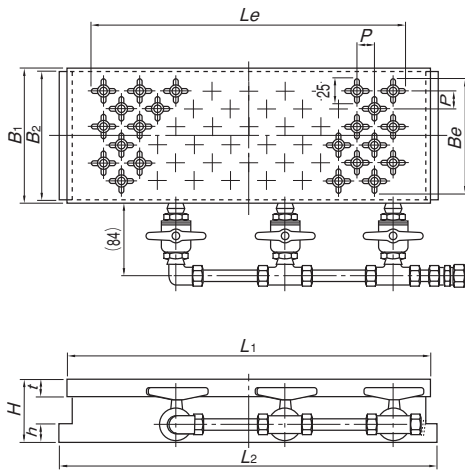
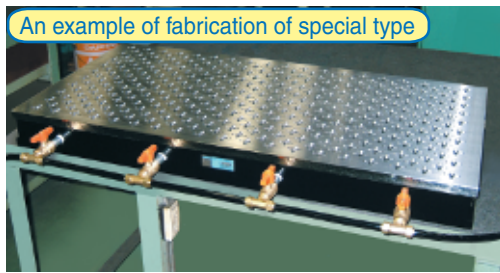
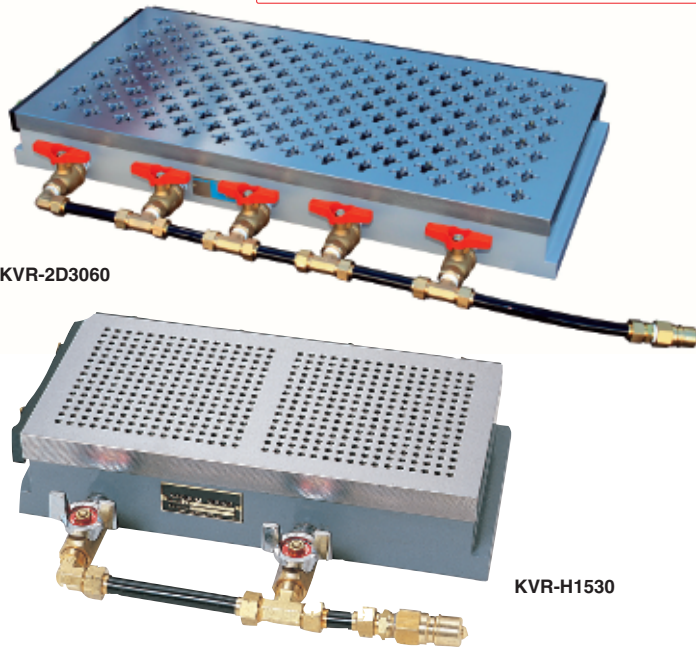

[Application]

Chucks to hold workpieces by utilizing atmospheric pressure. Nonferrous and nonmagnetic materials can be held and machined. These chucks are suitable for grinding and cutting plastics and grinding aluminum, brass, stainless steel, ceramic and glass.

[Features]

- The suction holes on the chuck work face can be arranged to set an effective holding area according to shapes of workpieces by combined adjustment of thread valves and valves.
- The suction holes have cross grooves to expand the acting area. Thus, fewer thread valves are used to improve the work efficiency.
- The chuck work face is made of iron to allow self-grinding to recover parallelism.
- Since the chuck work face is made of iron, magnetic devices such as workpiece stoppers can be utilized.
- A special suction hole layout adapter can be installed according to workpieces and work procedures.
- These chucks can be mounted on magnetic chucks.
- Since no heat source or moving parts are used inside the chucks, highly precise machining is ensured.

■ KVR-D (Thread valve type)

- An effective holding area can be set according to shapes of workpieces by combined adjustment of thread valves and valves.
- Since suction grooves of cross shape are provided on the holding face, the number of thread valves has been reduced to enhance the work efficiency.

■ KVR-H (Small hole type)

- Holes of $\phi 4$ are provided on the holding face at 8-mm pitches.

<Precautions for use>

The vacuum chuck is of such construction that the inside of the chuck is evacuated by a vacuum pump to reduce the internal pressure and a workpiece is held by atmospheric pressure. Therefore, the holding power is determined by a difference between the internal pressure and atmospheric pressure and the holding area. Due to physical restrictions, a difference in pressure that can be obtained by a pump is about 80 kPa (600 mmHg) in consideration of the upper limit of available evacuation efficiency. Since the same holding power as about 80 kPa (0.8 kgf/cm²) can be obtained, if the holding area of a workpiece is 100 cm², it is held by a holding power of about 800 N (80 kgf). Note, however, that if the holding face of workpieces is rough or distorted, even if slightly, atmospheric pressure leak occurs to decrease the holding power significantly. For such workpieces, some leak preventing measures must be taken. Workpieces could be deformed by heat generated during machining depending on materials and thickness of workpieces. Pay attention to machining methods. In particular, thin stainless steel sheets deform due to machining heat largely and are difficult to hold. If you have questions, please contact us.

Model	Nominal Size	Work Face					Hole Pitch	Mounting Face			Height	Mass	Applicable Vacuum System				
		B ₁	L ₁	t	B _e	L _e		B ₂	L ₂	h							
KVR-2D1018	100(3.93) × 175(6.89)	100(3.93)	175(6.89)	20 (0.78)	85(3.34)	145(5.70)	P=20 (Staggered layout) (0.78)	96(3.78)	195(7.67)	20 (0.78)	70 (2.75)	9kg/ 19 lb	VPU-E10 VPU-E20 VPU-D20				
KVR-2D1325	125(4.92) × 250(9.84)	125(4.92)	250(9.84)		105(4.13)	225(8.85)		121(4.76)	270(10.6)			15kg/ 33 lb					
KVR-2D1515	150(5.90) × 150(5.90)	150(5.90)	150(5.90)		125(4.92)	245(9.64)		170(6.69)	320(12.6)			11kg/ 24 lb					
KVR-2D1530	150(5.90) × 300(11.8)		300(11.8)		245(9.64)	320(12.6)		470(18.5)	22kg/ 48 lb								
KVR-2D1545	150(5.90) × 450(17.7)	200(7.87)	450(17.7)		405(15.9)	305(12.0)		370(14.5)	33kg/ 72 lb			VPU-E20 VPU-D20					
KVR-2D2035	200(7.87) × 350(13.7)		350(13.7)		185(7.28)	305(12.0)		196(7.71)	370(14.5)				34kg/ 74 lb				
KVR-2D2050	200(7.87) × 500(19.6)		500(19.6)		465(18.3)	520(20.4)		49kg/108 lb									
KVR-2D3060	300(11.8) × 600(23.6)		300(11.8)		600(23.6)	285(11.2)		545(21.4)	296(11.6)				620(24.4)	88kg/194 lb			
KVR-H1018	100(3.93) × 175(6.89)	100(3.93)	175(6.89)		20 (0.78)	72(2.83)		125(4.92)	P=8 (0.31)			96(3.78)	195(7.67)	20 (0.78)	70 (2.75)	9kg/19 lb	VPU-E10 VPU-E20 VPU-D20
KVR-H1325	125(4.92) × 250(9.84)	125(4.92)	250(9.84)			92(3.62)		205(8.07)				121(4.76)	270(10.6)			15kg/33 lb	
KVR-H1515	150(5.90) × 150(5.90)	150(5.90)	150(5.90)	125(4.92)		105(4.13)	170(6.69)	320(12.6)		11kg/24 lb							
KVR-H1530	150(5.90) × 300(11.8)		300(11.8)	252(9.92)		320(12.6)	22kg/48 lb										

*Clamp parts are included.

*Clamp parts are included.

ELECTROMAGNETIC CHUCKS

CHUCK CONTROLLERS

PERMANENT ELECTROMAGNETIC CHUCKS

PERMANENT ELECTROMAGNETIC CHUCKS

BLOCKS FOR MC

VACUUM CHUCKS

PROMELTA* SYSTEM

SINE BAR CHUCKS

BLOCKS, HOLDERS, MINI CHUCKS

HOLDING TOOLS

MEASURING TOOL HOLDERS

MAGNETIC HOLDERS

MAGNETIC TOOLS

VACUUM CHUCKS

Model KVR-AV AUTO VALVE TYPE VACUUM CHUCK

An epoch-making vacuum chuck that requires no masking!

Vacuum system required additionally



KVR-AV1530

Patented

(Technical tie-up with Taiyo Tec Company)

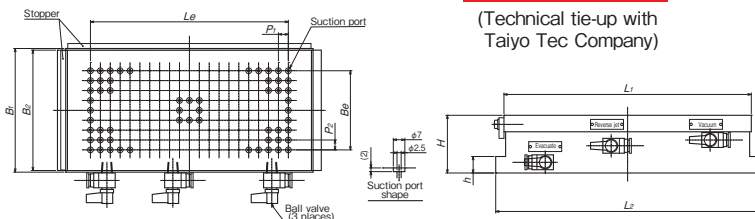

[Application]

Nonferrous and nonmagnetic materials can be held and machined. These chucks are suitable for grinding plastics, aluminum, brass, stainless steel, ceramic and glass by machine tools. They can also be used for light duty cutting if workpieces can be held firmly.

[Features]

- No masking is required to reduce the setup time:
Place a workpiece, apply grinding fluid and turn the valve. That is all required. Since the suction holes outside the workpiece are automatically closed, troublesome masking is not required and grinding can be started soon.
- Easy valve cleaning:
An original modular design that causes little clogging due to sludge facilitates maintenance to reduce the running cost.
- Enhanced safety:
An original construction is employed that closes the auto valve instantly should a workpiece move during grinding. This design causes no vacuum break and maintains a certain level of holding power.
- Dry operations supported:
In dry grinding operations using no grinding fluid, the chuck can be used with minimum necessary masking only.

[mm (in.)]

Model	Nominal Size	Work Face				Suction Port Pitch		No. of Suction Ports	Mounting Face		Height	Mass	Applicable Vacuum System	
		B ₁	L ₁	B _e	L _e	P ₁	P ₂		B ₂	L ₂				h
KVR-AV1018	100 (3.93) × 175 (6.89)	100 (3.93)	175 (6.89)	57.5 (2.26)	132 (5.20)	12 (0.47)	11.5 (0.45)	72	98 (3.86)	195 (7.68)	20 (0.79)	70 (2.75)	8kg / 17.6 lb	VPU-E10-AV
KVR-AV1530	150 (5.90) × 300 (11.8)	150 (5.90)	300 (11.8)	96 (5.67)	240 (9.45)			188	146 (5.75)	320 (12.6)			18kg / 39.7 lb	
KVR-AV2040	200 (7.87) × 400 (15.7)	200 (7.87)	400 (15.7)	144 (6.89)	348 (13.7)			388	196 (7.71)	420 (16.5)			30kg / 66.1 lb	
KVR-AV3060	300 (11.8) × 600 (23.6)	300 (11.8)	600 (23.6)	228 (8.97)	540 (21.2)			908	296 (11.6)	620 (24.4)			66kg / 145.5 lb	

*KVR-AV1530, KVR-AV2040 and KVR-AV3060 have places where no suction ports are provided partially. *Clamp parts are included.

Model VPU-E-AV VACUUM SYSTEM DEDICATED TO AUTO VALVE TYPE VACUUM CHUCK

Dry/wet operations



VPU-E10-AV

[Application]

A vacuum system dedicated to the auto valve type vacuum chucks. The shuck side is evacuated continuously in order to effectively maintain the atmospheric pressure on the workpiece on the chuck work face.

[Features]

- A vacuum evacuation system, filter, vacuum tank and vacuum gage are incorporated neatly.
- Since connectors are provided, the pipes of vacuum and reverse jet required for control of the vacuum chuck can be connected easily.
- A difference in pressure over 80 kPa (600 mmHg) can be obtained continuously.

[mm (in.)]

Model	Evacuation Volume	Continuous Pressure	Suction Port	Compressed Air			Dimensions		Tank Capacity	Mass
				Pressure	Consumption	Supply port	Out Dia.	Height		
VPU-E10-AV	110N ℓ /min	(80 kPa (600 mmHg) or over)	3/8	500—600kPa (5—6kgf/cm ²)	180N ℓ /min	1/4	φ277 (10.9)	425 (16.7)	15 ℓ	25kg / 55 lb

*The capacity of a compressor to use must be 2.5 kW or over. φ12 hose, 10 m long, is included as an accessory.

Piping of vacuum system

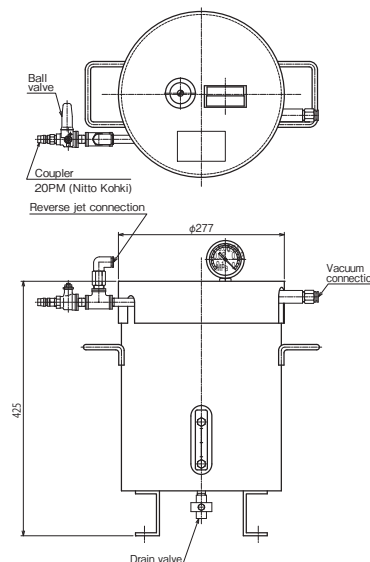
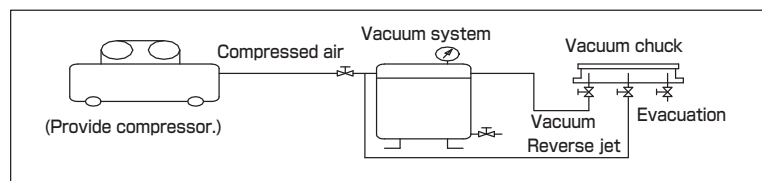

Model **KVR-GV** VACUUM CHUCK WITH BUILT-IN VACUUM SYSTEM

No external vacuum system required!
Air consumption reduced significantly!

Dry operation
(Wet operation not allowed)



KVR-GV1530

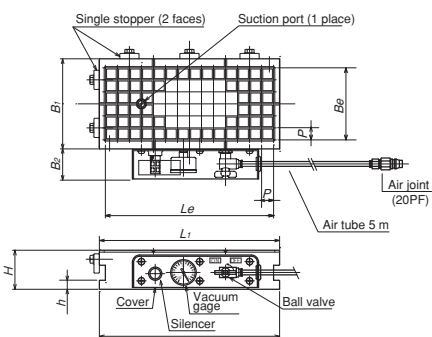

[Application]

Suitable for light duty cutting by vacuum chucking such nonmagnetic workpieces as aluminum alloy, copper alloy, stainless steel and plastics.

[Features]

- Compared with the conventional ejector vacuum system, the air consumption amount can be reduced significantly.
- The chuck can be used by simply connecting a quick-connector type tube to a compressor in the factory.
- Since no vacuum system is required, the chuck has good response and is capable of holding and releasing workpieces quickly.
- The internal parts can be replaced easily by opening the lid on the chuck mounting face.
- The material of the main unit can be selected from two kinds; mild steel and aluminum alloy.

Model	Main Unit Material	Nominal Size	Dimensions							Grid Pitch	Effective Area	Mass
			L ₁	L ₂	B ₁	H	h	B ₂	P×P			
KVR-GV1530	Mild steel	150(5.90) × 300(11.8)	300(11.8)	300(11.8)	150(5.90)	65(2.55)	15(0.59)	50(1.96)	20(0.78) × 20(0.78)	120(4.72) × 280(11.0)	17kg/37 lb	
KVR-GV2050		200(7.87) × 500(19.7)	500(19.7)	524(20.6)	200(7.87)					180(7.08) × 480(18.8)	43kg/94 lb	
KVR-GV3060		300(11.8) × 600(23.6)	600(23.6)	624(24.5)	300(11.8)					25(0.98) × 25(0.98)	275(10.8) × 575(22.6)	82kg/180 lb
KVR-GVA1530	Aluminum alloy	150(5.90) × 300(11.8)	300(11.8)	300(11.8)	150(5.90)	65(2.55)	15(0.59)	50(1.96)	20(0.78) × 20(0.78)	120(4.72) × 280(11.0)	6kg/13 lb	
KVR-GVA2050		200(7.87) × 500(19.7)	500(19.7)	524(20.6)	200(7.87)					180(7.08) × 480(18.8)	15kg/33 lb	
KVR-GVA3060		300(11.8) × 600(23.6)	600(23.6)	624(24.5)	300(11.8)					25(0.98) × 25(0.98)	275(10.8) × 575(22.6)	29kg/63 lb

*Seal rubber φ4, 10 m, air tube 5 m and clamp parts are included. *The capacity of a compressor to use must be 0.75 kW or over.

Model **KVR-G** VACUUM CHUCK (GRID SEAL TYPE)



KVR-G1530

[Application]

Suitable for grinding by vacuum chucking such nonmagnetic workpieces as aluminum alloy, copper alloy, stainless steel and plastics.

[Features]

- Workpieces are vacuum chucked in the area defined by seal rubber strings set in the grid grooves, ensuring good sealing and consistent holding power.
- A desired work area can be set by cutting the seal rubber string (φ6 × 5 - 20 m included) according to workpieces.
- The suction ports are provided in two places on all models to allow setting two workpieces.
- A vacuum coupler to connect to the vacuum system is provided. (Vacuum is turned on and off with the valve on the vacuum system.)
- Single stoppers are provided.
- The main unit is made of iron to enable the chuck to be held by an existing magnetic chuck.

Vacuum system required additionally

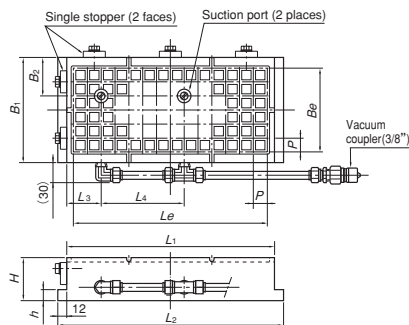

See "Model KETV:ELECTROMAGNETIC CHUCK WITH VACUUM CHUCK" on page 11.

Model	Nominal Dimensions	Dimensions							Grid Pitch	Effective Area	Mass	Applicable Vacuum System
		L ₁	L ₂	B ₁	H	h	B ₂	L ₃				
KVR-G1530	150(5.90) × 300(11.8)	300(11.8)	324(12.7)	150(5.90)	60(2.36)	15(0.59)	55(2.16)	50(1.96)	120(4.72)	20×20(0.78×0.78)	120(4.72) × 280(11.0)	22kg/48 lb
KVR-G2050	200(7.87) × 500(19.7)	500(19.7)	524(20.6)	200(7.87)			50(1.96)		220(8.66)		180(7.08) × 480(18.8)	
KVR-G3060	300(11.8) × 600(23.6)	600(23.6)	624(24.5)	300(11.8)			63(2.48)	63(2.48)	275(10.8)	25×25(0.98×0.98)	375(14.7) × 775(30.5)	275(10.8) × 575(22.6)
KVR-G4080	400(15.7) × 800(31.5)	800(31.5)	824(32.4)	400(15.7)	63(2.48)	63(2.48)	350(13.7)	475(18.7)	25×25(0.98×0.98)	375(14.7) × 775(30.5)	475(18.7) × 975(38.3)	146kg/321 lb
KVR-G50100	500(19.7) × 1000(39.4)	1024(40.3)	500(19.7)	475(18.7)			228kg/503 lb					

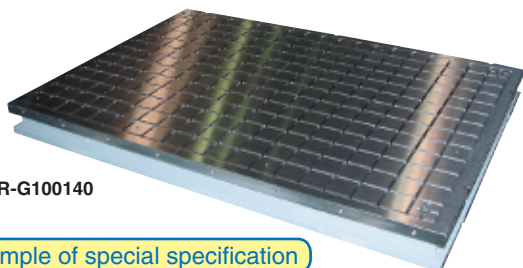

KVR-G100140

An example of special specification



KVR-GR

An example of KVR-GR special specification

An example of special specification

ELECTROMAGNETIC CHUCKS
CHUCK CONTROLLERS
PERMANENT MAGNETIC CHUCKS
BLOCKS FOR MC
VACUUM CHUCKS
PROMELTA* SYSTEM
SINE BAR CHUCKS
BLOCKS, HOLDERS, MINI CHUCKS
HOLDING TOOLS
MEASURING TOOL HOLDERS
MAGNETIC HOLDERS
MAGNETIC TOOLS

Model VPU VACUUM SYSTEM

Dry/wet operations

Dry operation
(Wet operation not allowed)

[Application]

A vacuum system dedicated to the vacuum chucks. The chuck side is evacuated continuously in order to effectively maintain atmospheric pressure on the workpiece on the chuck work face. Note that this system must not be modified to a pressure container.

[Features]

- A vacuum evacuation system, filter, vacuum tank and vacuum gage are incorporated neatly.
- Suction and evacuation operations to mount and demount workpieces can be done quickly and easily with the attached special operating handle.
- A difference in pressure over 80 kPa (600 mmHg) can be obtained continuously.

Ejector type VPU-E

A vacuum system to reduce pressure by jetting air at high pressure (principle of the spray gun). This is recommended where an air line by use of a compressor is installed. This type can be used for both wet and dry machining operations. However, the use of a lubricator in the air line must be avoided.

Dry pump type VPU-D

A vacuum system to reduce pressure by evacuation by a pump driven by a motor. A power source only is required to obtain an independent vacuum source. Note, however, this is recommended only for dry machining operations.

Other types

If the physical contact with the bottom face of workpieces is poor, a large amount of air leaks, requiring a large evacuation amount. In such a case, a blower type is required for dry operations and a water-sealed vacuum pump is required for wet operations depending on work conditions. Please contact us.

Examples of application of vacuum chucks and vacuum systems

Pump	Chuck	1018	1325	1515	1530	1545	2035	2050	3060
VPU-E10		○	○	○	○	—	—	—	—
VPU-E20		○	○	○	○	○	○	○	○
VPU-D20		○	○	○	○	○	○	○	○

Piping of vacuum system

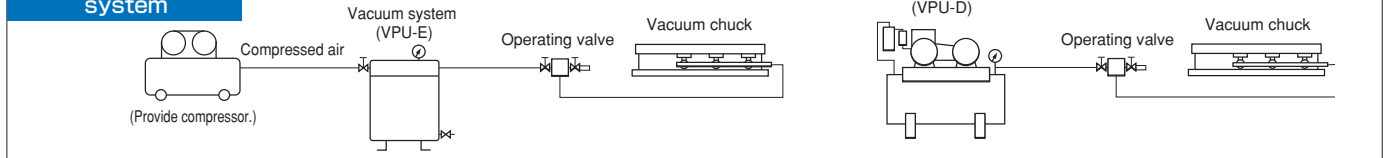

Ejector type VPU-E

Model	Evacuation Volume	Continuous Pressure Difference	Suction Port	Compressed Air		Dimensions			Tank Capacity	Mass
				Pressure	Consumption	Supply port	Out. dia.	Height		
VPU-E10	110N ℓ /min	80 kPa (600 mmHg) or over.	3/8	500-600kPa (5-6kgf/cm ²)	180N ℓ /min	1/4	φ280 (11.0)	425 (16.7)	15 ℓ	25kg/55 lb
VPU-E20	220N ℓ /min				360N ℓ /min	3/8	φ330 (12.9)	600 (23.6)	30 ℓ	45kg/99 lb

※ The capacity of a compressor to use must be 2.5 kW or over for VPU-E10 and 4.5 kW or over for VPU-E20. ※ (1) Operating valve and (2) φ12 hose 10 m are included as accessories.

Dry pump type VPU-D (for dry operations)

Model	Evacuation Volume	Continuous Pressure Difference	Suction Port	Power Source	Dimensions			Tank Capacity	Mass
					Width	Length	Height		
VPU-D20	220/260N ℓ /min (50/60Hz)	80 kPa (600 mmHg) or over	3/8	3-phase 200 VAC, 0.4 kW	320 (12.6)	680 (26.7)	690 (27.1)	35 ℓ	68kg/149 lb

※ (1) Operating valve, (2) φ12 hose 10 m and (3) power cable 5 m are included as accessories.

Model VPU-EG VACUUM SYSTEM

Light weight and compact. Satisfactory functions!

[Application]

A vacuum system dedicated to the grid seal type vacuum chucks.

[Features]

- The vacuum tank has been eliminated to make a very compact size compared with the conventional model (VPU-E10). This system can be handled easily.
- A function to check the vacuum status is incorporated.
- This is for dry operation.
- Auxiliary functions in consideration of operating status and safety are incorporated. (Vacuum adjustment, interlock with the machine via vacuum check output signals, etc.)



VPU-EG

Model	Evacuation Volume	Continuous Pressure Difference	Suction Port	Compressed Air			Dimensions			Mass
				Pressure	Consumption	Supply port	Out. dia.	Length	Height	
VPU-EG	27N ℓ /min	80 kPa (600 mmHg) or over.	φ8 tube joint (Hose and vacuum coupler included)	500-600kPa (5-6kgf/cm ²)	44N ℓ /min	Vacuum coupler 20PM (Nitto Kohki)	200 (7.87)	250 (9.84)	190 (7.48)	6kg/13.2 lb

※ The capacity of a compressor to use must be around 0.75 kW.

Model VPU-OV OPERATION BLOCK WITH VACUUM GAGE

VPU-OV

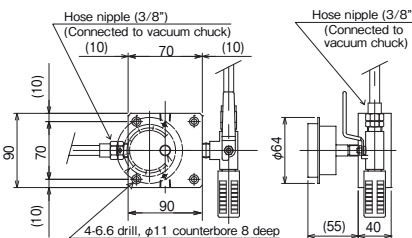

[Application]

An option to facilitate the use of vacuum chucks.

[Features]

- The operating valve and the vacuum gage have been integrated to enable it to check the state of workpiece holding near the chuck.
- By changing the location of the blank cap, a position to mount the vacuum gage can be selected from three places.

ELECTROMAGNETIC CHUCK CONTROLLERS : MAGNETIC CHUCKS : PERMANENT CHUCKS : PERMANENT CHUCKS : ELECTROMAGNETIC CHUCKS : BLOCKS FOR MC : VACUUM CHUCKS : PROMETA* : SINE BAR CHUCKS : BLOCKS, HOLDERS, MINI CHUCKS : HOLDING TOOLS : MEASURING TOOL HOLDERS : MAGNETIC HOLDERS : MAGNETIC TOOLS