

Model KMDE STATIONARY DEMAGNETIZER

Control unit required additionally



KMDE-1212



EHD-W205B

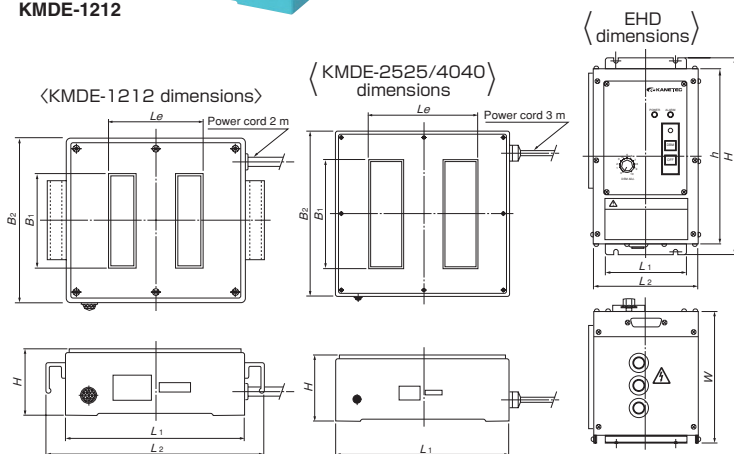

[Application]

Used to eliminate residual magnetism in magnetized workpieces and tools. Pressing the demagnetizing button can complete demagnetization within a certain time without moving workpieces.

[Features]

- A magnetomotive force greater than the AC demagnetizer has been set, which works well on hard workpieces such as bearing steel and cutter steel that are difficult to demagnetize with conventional demagnetizers.
- Since workpieces are demagnetized while they are kept stationary on the demagnetizer, it is not necessary to move workpieces, press die materials, SK materials, etc. as when using an AC demagnetizer. Thus, this model is suitable for demagnetization of large workpieces (e.g. molds) that are difficult to move.
- Since demagnetization is carried out according to the attenuation pattern programmed in the control unit, electricity needs to be applied only during demagnetization, thus saving electricity.
- The demagnetizer itself and the control unit are installed separately. Thus, they can be installed in an easy-to-operate place.

A larger special demagnetizer is also available.

Main unit

Model	Dimensions						Demagnetizing Area	Withstand Load	Electrical Rating	Working Rate	Mass
	L ₁	L ₂	L _e	B ₁	B ₂	H					
KMDE-1212	230 (9.05)	280 (11.0)	120 (4.72)	120 (4.72)	210 (8.26)	85 (3.34)	120 (4.72) × 120 (4.72)	20kg/ 44 lb	180 VDC/ 2.1A	25% ED	15kg/ 33 lb
KMDE-2525	400 (15.7)	—	250 (9.84)	250 (9.84)	380 (14.9)	150 (5.90)	250 (9.84) × 250 (9.84)	80kg/ 176 lb	180 VDC/ 4.8A		75kg/ 165 lb

※The withstand load is based on a uniform load in the work area.

Main unit

Model	Dimensions					Demagnetizing Area	Withstand Load	Electrical Rating	Working Rate	Mass
	L ₁	L _e	B ₁	B ₂	H					
KMDE-4040	640 (25.2)	400 (15.7)	400 (15.7)	640 (25.2)	220 (8.66)	400 (15.7) × 400 (15.7)	300kg/ 661 lb	180 VDC/ 9A	25% ED	350kg/ 771 lb

※The withstand load is based on a uniform load in the work area.

Applicable control unit (KMDE-1212/2525)

Model	Dimensions					Power	Output	Mass
	L ₁	L ₂	W	H	h			
EHD-W205B	110 (4.33)	140 (5.51)	175 (6.89)	260 (10.2)	230 (9.05)	Single-phase 200 VAC	180 VDC/ 5A	4.7kg/ 10 lb

Applicable control unit (KMDE-4040)

Model	Dimensions					Power	Output	Mass
	L ₁	L ₂	W	H	h			
EHD-W210B	190 (7.48)	220 (8.66)	175 (6.89)	290 (11.4)	250 (9.84)	Single-phase 200 VAC	180 VDC/ 10A	6kg/ 13 lb

Model KMDE-MP SINGLE POLE STATIONARY DEMAGNETIZER

Control unit required additionally



KMDE-MP1013

[Application]

Recommended for demagnetization of thick workpieces and demagnetization of large workpieces partially. Pressing the demagnetizing button can complete demagnetization within a certain time without moving workpieces.

[Features]

- A strong magnetic field is produced in a wide area to make this model suitable for demagnetization of thick workpieces and demagnetization of large workpieces partially.
- Since demagnetization is carried out according to the attenuation pattern programmed in the control unit, electricity needs to be applied only during demagnetization, thus saving electricity.
- The demagnetizer itself and the control unit are installed separately. Thus, they can be installed in an easy-to-operate place.

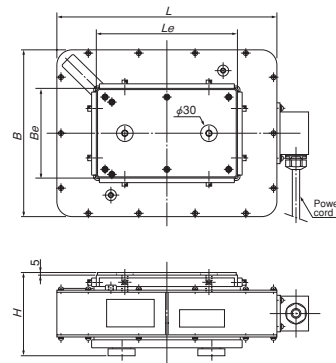

Model	Dimensions			Demagnetizing Area	Electrical Rating	Working Rate	Mass	Applicable Control Unit
	L	B	H					
KMDE-MP1013	240 (9.44)	210 (8.26)	110 (4.33)	100 (3.93) × 130 (5.11)	180 VDC/2.1A	25% ED	20kg/ 44 lb	EHD-W205B
KMDE-MP1625	390 (15.3)	300 (11.8)	150 (5.90)	160 (6.29) × 250 (9.84)	180 VDC/4.7A		75kg/165 lb	
KMDE-MP2040	580 (22.8)	380 (14.9)	185 (7.28)	200 (7.87) × 400 (15.7)	180 VDC/7.8A		170kg/375 lb	

※KMDE-MP1013 comes with a 2 m power cord and other models with a 3 m cord.

MAGNETIC TOOLS & EQUIPMENT FOR FINISHING OPERATION
LIFTING MAGNET
MAGBORE
MAGNETIZER AND DEMAGNETIZER
ENVIRONMENTAL CHIP & SLUDGE CONFORMANCE EQUIPMENT
MAGNETIZER AND DEMAGNETIZER
MAGNETIC EQUIPMENT FOR CONFORMANCE
MAGNETIC SEPARATORS
POWERFUL MAGNETIC SEPARATORS
MEASURING INSTRUMENTS TOOLS
MAGNETIC MATERIALS