

# LIFTING MAGNETS

## Model LM-EC LARGE ELECTROMAGNETIC LIFMA\*

**Control unit required additionally**

(Quoted when requested)

### [Application]

Suitable for transporting mainly iron wastes and iron lumps such as scraps, slabs and ingots.

### [Features]

- Designed with the electromagnetic coil in H-grade insulation for maximum magnetic effect and minimum power consumption.
- Robust and tough, designed to withstand severe operations.

※LM-40EC2 has no chain. (Eyebolt included)

※An output voltage variable unit and uninterruptible power supply are available according to applications.

LM-90EC2



### An example of usage

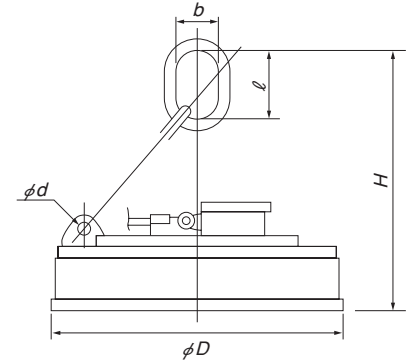

[mm (in)]

Model	Max. Lifting Mass				Dimensions						Voltage	Current	Power Consumption	Mass	Applicable Control Unit	Working Rate
	Ingot	Pig iron	Steel cut wastes	Chips	D	H	b	l	d							
LM-40EC2	1000kg/ 2205 lb	60kg/ 132 lb	20kg/ 44 lb	10kg/ 22 lb	400 (15.7)	—	—	—	— <sup>※1</sup>	220 VDC	2.5A	0.55kW	130kg/ 286 lb	LBR-04E	50%ED Repeating cycle of power on 5 min. and pause 5 min.	
LM-50EC2	1800kg/ 3968 lb	120kg/ 264 lb	90kg/ 198 lb	25kg/ 55 lb	500 (19.6)	600 (23.6)	70 (2.75)	140 (5.51)	18 (0.70)		4.3A	1.0kW	290kg/ 639 lb	LBR-05E		
LM-60EC2	3000kg/ 6614 lb	250kg/ 551 lb	120kg/ 264 lb	40kg/ 88 lb	600 (23.6)	740 (29.1)	90 (3.54)	160 (6.29)	—		5.8A	1.3kW	400kg/ 880 lb	LBR-06E		
LM-70EC2	5000kg/ 11020 lb	350kg/ 771 lb	200kg/ 441 lb	100kg/ 220 lb	700 (27.5)	820 (32.2)	110 (4.33)	180 (7.08)	22 (0.86)		18A	4.0kW	—	LBR-07E		
LM-90EC2	9000kg/ 19840 lb	500kg/ 1102 lb	300kg/ 661 lb	200kg/ 441 lb	900 (35.4)	1060 (41.7)	150 (5.90)	220 (8.66)	28 (1.10)		28A	6.2kW	740kg/ 1631 lb	LBR-09E		
LM-110EC2	14000kg/ 30860 lb	900kg/ 1984 lb	500kg/ 1102 lb	300kg/ 661 lb	1100 (43.3)	1140 (44.8)	175 (6.88)	250 (9.84)	32 (1.25)		42A	9.2kW	1250kg/ 2756 lb	LBR-11E		
LM-130EC2	19000kg/ 41890 lb	1400kg/ 3086 lb	800kg/ 1764 lb	500kg/ 1102 lb	1300 (51.1)	1250 (49.2)	190 (7.48)	290 (11.4)	38 (1.49)		63A	13.9kW	2000kg/ 4410 lb	LBR-13E		
LM-150EC2	24000kg/ 52910 lb	1900kg/ 4189 lb	1100kg/ 2425 lb	800kg/ 1764 lb	1500 (59.0)	1480 (58.2)	210 (8.26)	350 (13.7)	44 (1.73)		74A	16.3kW	3000kg/ 6615 lb	LBR-15E		
LM-180EC2	31000kg/ 68340 lb	2700kg/ 5952 lb	1600kg/ 3527 lb	1100kg/ 2205 lb	1800 (70.8)	1620 (63.7)	230 (9.05)	370 (14.5)	54 (2.12)		110A	24.0kW	5300kg/ 11686 lb	LBR-18E		

※1: M42 eyebolt ※The control unit carries an operation pushbutton switch, instrument box, cable connector and cable reel.

## Model LM-R RECTIFIER BUILT-IN LARGE ELECTROMAGNETIC LIFMA\*

### An example of special type



LM-R60-S

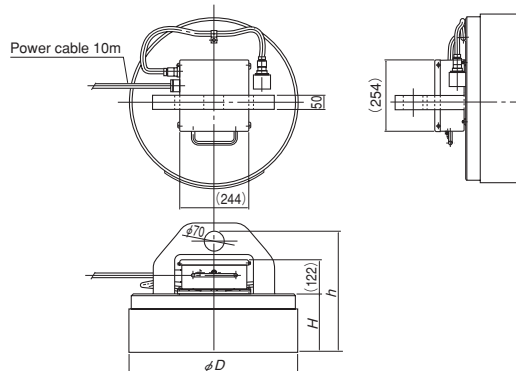

### [Application]

Suitable for lifting steel plates and scraps.

### [Features]

- These Lifmas incorporate a rectifier and therefore require no control unit to be installed separately.
- When the rectifier is removed, remote operation becomes possible. (The remote operation cable, however, is optional.)
- A drip-proof construction for use outdoors.
- ※If the rectifier is secured on a wall, the construction is no more drip-proofed.
- The built-in reverse excitation circuit facilitates releasing lifted workpieces.

[mm (in)]

Model	Max. Lifting Mass				Holding Power (Max.)	Dimensions			Input Voltage	Power Consumption	Working Rate	Mass
	Ingot	Pig Iron	Steel cut wastes	Chips		D	H	h				
LM-R45	1200kg/2646 lb	40/88— 70kg/154 lb	20/44— 40kg/ 88 lb	15kg/33 lb	56kN ( 5600kgf)	450 (17.7)	170 (6.69)	395 (15.5)	200 VAC	1 φ Approx.420W	50% ED	220kg/485 lb
LM-R60	2000kg/4409 lb	100/220— 150kg/330 lb	60/132— 100kg/220 lb	20kg/44 lb	100kN (10000kgf)	600 (23.6)	205 (8.07)	430 (16.9)	200 VAC	1 φ Approx.750W	50% ED	400kg/880 lb